

A guide to select the correct bell-housing and drive coupling components

DATA REQUIRED

Electric motor power/motor size
Manufacturer and pump type

TO VERIFY:

- 1 - Pump and motor shaft dimensions (see page 69)
- 2 - Shaft and flange pump (see pump data sheet)

Example:

- Electric motor 2 kW - 4 poles - Motor size 110/112
- Atos pump code PFE31 - Shaft 1

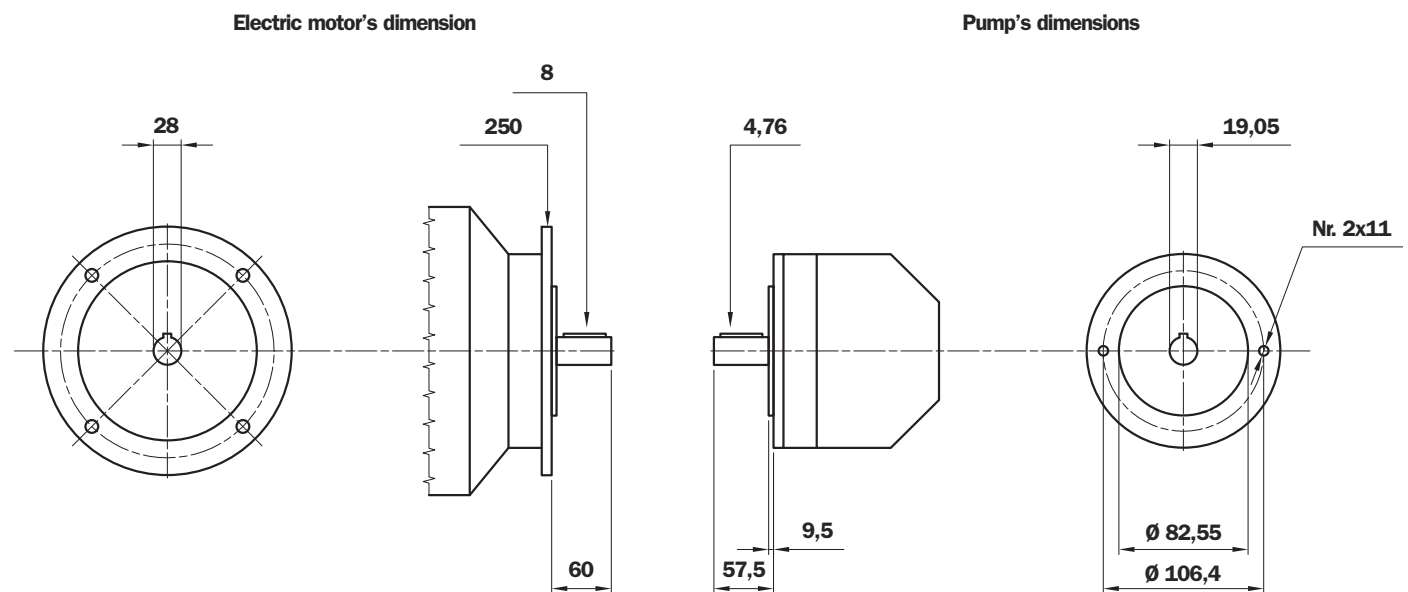

Bell-Housing's length calculation

- $H = 60 + 18 + 57,5 = 135,5$ mm (18= Sp spider - see page 49)
- Choose type of bell-housing (LMC - LMS)
 - For LMC see tab. 3 at page 11
 - For LMS see tab. 21 at page 32
 - For MODUL 2/3 see at page 36

Note: The length of bell-housing must be \geq than the length calculated (135,5 mm)

Case A - solution with LMC bell-housing

Tab. 3 at page 11 - for electric motor 2kW LMC 250
LMC 250 bell-housing with height $\geq 135,5$ - LMC250AFSQ

- The bell-housing code must be completed with drilling pump code (see tab. 34 at page 47)
For the specific case C= 101,6 - Nr. 2 holes M10: Code drilling 070
- Definitive bell-housing code **LMC250AFSQ070**

Case B - solution with LMS bell-housing

Tab. 21 at page 32 - for electric motor 2kW LMS 250
LMS 250 bell-housing with height $\geq 135,5$ - LMS250AFSQ

- The bell-housing code must be completed with drilling pump code (see tab. 34 at page 47)
For the specific case C= 101,6 - Nr. 2 holes M10: Code for. 070
- Definitive bell-housing code **LMS250AFSQ070**

Choose coupling

- **Motor half-coupling** (see tab. 37 at page 50)
 - For electric motor GR 100/112, the half-coupling is **SGEA21M05060**
- **Spider** (see tab. 35 - 36 at page 49)
 - For SGEA21, EGE2 - EGE2RR
(choose spider material on the base of the application, oil, temperature and cycle machine, etc.)
- **Pump half-coupling**
 - Choose the drilling code tab. 43 - 44 at page 53 for shaft 19,05 - Ch. 4,76 - code: **G01**
 - Half-coupling length = L BH length - THK Spider - THK Spigot
 $138 \text{ mm} - 60 - 18 - 9,5 = 50,5 \text{ mm}$
 - Choose the half-coupling's length on tab. 38 at page 50 $\leq 50,5 \text{ mm}$.
 - Availabe length for SGEA21= 50 mm
 - Code half-coupling code: **SGEA21G01050**

**Software for automatic calculation available on the web site
www.mpfiltri.com - tools - software**

The screenshot shows the MP Filtri software interface for selecting a coupling. It is divided into several sections:

- AKA:** AKM0320068
- Pump:**
 - Manufacturer: ATOS
 - Pump type: PFE
 - Pump model: PFE31 Shaft 1
- HYDRAULIC PUMP - Technical Data:**
 - L1: 57.5
 - d1: 19.05
 - Ch1: 4.76
 - E: 9.5
 - M1: 82.55
 - B1: 106
 - N1: 2
 - F: M10
- Electric Motor:**
 - N. Pole: 2P
 - Type: M3-B5
 - Size: 100-112
 - Sec: 3-4
 - tp: 4-5,44
- ELECTRIC MOTOR - Technical Data:**
 - L1: 60
 - M1: 28
 - Fig: 256
 - Ch: 8
- Coupling material:**
 - Aluminium
 - Cast iron
 - Other alternative material
- Result:**
 - Coupling: M01 - 21066
 - Drilling Pump: 5000
 - Pump Shaft: G01
 - Motor Shaft: M01
- Result (Bearing Housing):**
 - Monobloc Bearing housing: (Not OK)
 - Modular Bearing housing: (OK)
 - Silenced Bearing housing: (OK)
- Notes:**
 - Monobloc Bearing housing: Pump half-coupling with grub screw. For other solution please contact technical department.
 - Modular Bearing housing: OK
 - Silenced Bearing housing: OK
- CLICK HERE TO PROCEED**

Note: For multi pumps we recommend to use a specific support on the base of the pump's dimensions and weight.

Half-coupling SGE*** series

The half-couplings series SGE*** allow secure transmission between the electric motor and the driven side; they are able to absorb shocks and vibration, in addition to compensating radial misalignment, angular and axial.

The assembly of the couplings can be horizontal/vertical, withstanding vibration and load reversals.

The complete range of couplings are extrapolated from the on-line software, with a length equal than the shaft on which must be mounted and they are completed with grub screw for fixing located on the key.

Available for cylindrical shaft with metric and imperial dimensions as well for splined shafts as per specification DIN, ISO and SAE.

Admissible misalignment radial, angular and axial

Max admissible radial misalignment

Half coupling	R (mm)
SGE * 01	0,5
SGE * 21	1,0
SGE * 31	1,0
SGE * 40	1,0
SGE * 51	1,5
SGE * 60	1,5
SGE * 80	2,0
SGE * 90	2,0

Max admissible angular misalignment

Half coupling	β (°)
SGE * 01	
SGE * 21	
SGE * 31	
SGE * 40	1,5°
SGE * 51	
SGE * 60	
SGE * 80	
SGE * 90	

Max admissible angular misalignment

Half coupling	A (mm)
SGE * 01	2,0
SGE * 21	2,5
SGE * 31	3,0
SGE * 40	3,5
SGE * 51	3,5
SGE * 60	3,5
SGE * 80	4,0
SGE * 90	5,0

Normative ATEX 94/9/CE

Half-couplings SGE*** series are available to use in hazardous area.

The couplings are certified according to ATEX 94/9/CE (ATEX 95).

Category certified 2G - area 1 and 2.

Other information available on our web site "www.mpfiltri.com".

MP Filtri couplings are developed with:

CAD 3D



FEM (calculation)



Drawings 3D available on website www.mpfiltri.com at section TOOLS/2D-3D COMPONENTS

The half-couplings SGE*** series are in conformity to normative **DIN 740/2**.
The max torque to transmit is always less than the max torque that the coupling can transmit.

Examples verification of the coupling

Torque transmitted by electric motor:

Mt: $9560 \times \text{kW} / \text{rpm} = \text{Nm}$

Me > $\text{Mt} \times \text{S} = \text{Nm}$

Where:

Mt: Torque transmitted by electric motor

Me: Torque transmitted by coupling (see table 14)

kW: Power of electric motor

Rpm: Revolutions per minute of electric motor

S: Service factor (see table 14)

TABLE 1

Small pumps, uniform load, low operating pressures e.g. rotary action machine tools - 5/8 work cycles per hour	1.3
Small pumps, uniform load, high working pressures e.g. lifting equipment - 120-150 work cycles per hour	1.5
Pumps, non-uniform load e.g. lifting equipment - 280-300 work cycles per hour	1.7

Example

Electric motor, 4 pole - 4 kW

hydraulic pump, uniform load, low operating pressure

Mt: $9560 \times 4 / 1500 = 25.45 \text{ Nm}$

Me > $25.49 \times 1.3 = 33 \text{ Nm}$

Half-coupling SGEA21 meets the above requirement.

Select the half-coupling of the calculated size from the motor half-couplings table.

Note: When selecting the coupling, remember that for pumps with splined shaft, only cast iron couplings of the SGEG series can be used.

Determine the size of the coupling according to the type of installation and application envisaged, on the basis of the following formulas and tables:

TABLE 2

Half-coupling type	External diameter mm	Nominal torque Me - Nm	Maximum transmissible torque Me - Nm	
ALUMINIUM	SGEA01	43	15	20
	SGEA21	68	160	190
	SGEA31	85	340	380
	SGEA51	109,5	550	620
CAST IRON	SGEG01	40	20	30
	SGEG30	80	400	450
	SGEG40	95	550	620
	SGEG60	120	760	850
	SGEG80	160	2200	2500
	SGEG90	200	5500	6100
STEEL	SGES40	95	550	620
	SGES60	120	760	850
	SGES80	160	2200	2500

Nominal and maximum torque values are referred to couplings assembled with standard flexible spiders of the **EGE**** series (see page 49).

Where higher torques are to be transmitted, use flexible spiders of the **EGE**RR** series (see page 49).

Noise

Noise is a particularly pervasive problem so much so that there have been statutory regulations in place now for some years, designed to limit harmful occupational exposure. Many of the machines used in industry today are equipped with oil-hydraulic systems, which happen to be a major source of noise.

1. Theory and definition of noise

From a health and hygiene standpoint, noise can be defined as an unpleasant and undesirable sound, or an unpleasant and annoying or intolerable auditory sensation (noise being any sound phenomena that may be accompanied by sensations of disturbance and pain). By definition, acoustic phenomena are oscillatory in character, propagated in a flexible medium and causing pressure variations at the points, and the areas adjacent to those points, through which they pass.

2. Sound

Technically considered, certain elements must be present simultaneously for acoustic phenomena to occur:

- Sound source
- Transmission medium
- Receiver

Motor and pump unit

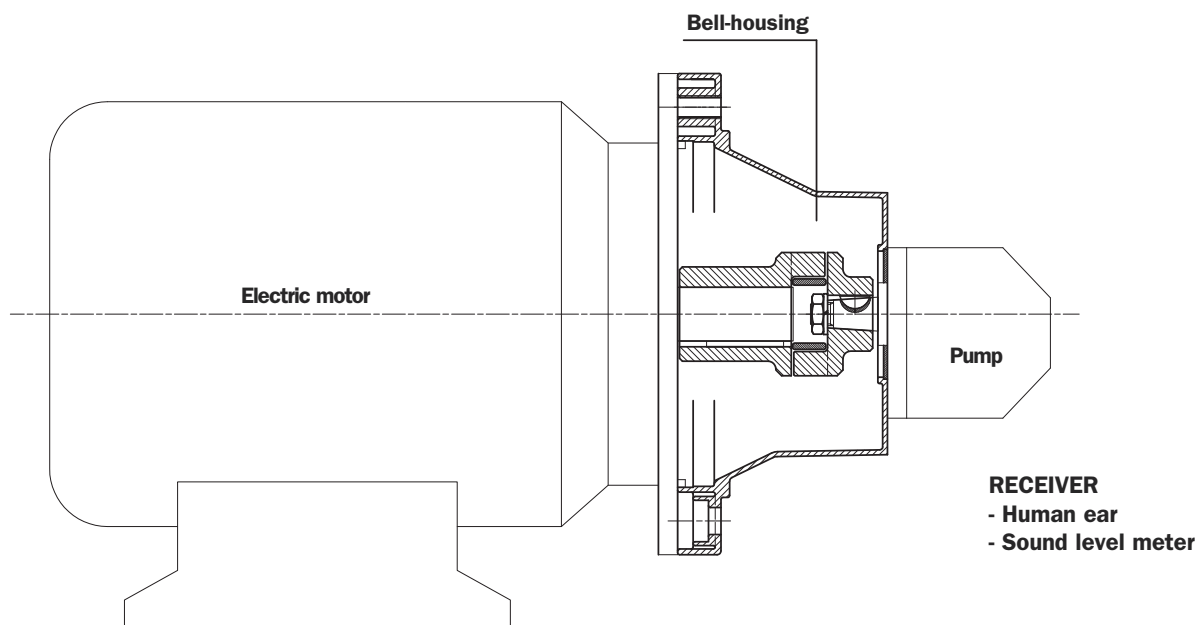

The **electric motor** and the **pump**, together with the drive coupling, are the **SOURCE OF THE NOISE**.

The **Bell-housing** is the noise transmission medium.

Depending on whether the monobloc bell-housing is a rigid or low noise type, there will be variations in the flexible properties of the transmission medium.

The acoustic phenomena are dissimilar in the two cases, given the differences in pressure variation and particle displacement.

Assembly of motor and pump unit

As mentioned in the presentation, low noise bell-housing will help to attenuate the transmission of vibrations and the emission of noise generated by the system.

Self-evidently, however, the mere adoption of a low noise bell-housing will achieve little unless the motor and pump are correctly installed on the machine, or on the tank of the hydraulic power unit.

- Should be followed in order to achieve best possible results and correct installation:

1. Motor and pump unit mounted horizontally on oil tank lid

- The suction pipe attached to the pump must be rigid, and fitted using a resilient bulkhead flange of the FTA series, which helps to cushion the vibrations propagated between the pipe and the tank lid. If pipes need to be bent, the radius of curvature must be at least 3 times the pipe diameter. Do not use elbow fittings, as these will significantly increase pressure losses.
- The pressure pipeline of the pump must be flexible, and long enough to include bends with the minimum radius of curvature recommended by the manufacturer for the specified operating pressure.
- The return pipeline running from the service to the filter must be flexible. Where oil is returned directly to the tank of the hydraulic power unit through a rigid pipe, it is advisable to use a resilient bulkhead flange of the FTR series, which helps to cushion the vibrations propagated between the pipe and the tank lid.
- Anti-vibration devices (resilient mounts or damping rods) must be located under the feet of the electric motor or the PDM foot brackets, depending on the mounting position of the motor.
- The lids of hydraulic oil tanks must be sturdy enough to support the load they carry.

2. Motor and pump unit mounted horizontally on machine

- As a matter of good practice, the oil tank and motor-pump unit should be mounted on a single supporting frame of strength sufficient to support the load.
- If the hydraulic system is fitted with a side-mounted filter, the suction pipeline to the pump must be flexible, and long enough to include bends with the minimum radius of curvature recommended by the manufacturer.
- If the suction filter is not side mounted, the pipeline should be rigid and installed in conjunction with a compensating coupling.
- The pressure pipeline of the pump must be flexible, and long enough to include bends with the minimum radius of curvature recommended by the manufacturer for the specified operating pressure.
- The return pipeline running from the service to the filter must be flexible. Where oil is returned directly to the tank of the hydraulic power unit through a rigid pipe, it is advisable to use a resilient bulkhead flange of the FTR series, which helps to cushion the vibrations propagated between the pipe and the tank lid.
- Anti-vibration devices (resilient mounts or damping rods) must be located under the feet of the electric motor or the PDM foot brackets, depending on the mounting position of the motor.

Note: The above guidelines are indicative only, and subordinate to the solutions adopted ultimately by design engineers.

In conclusion: For best results, in any event, the motor-and-pump unit should be incorporated into the hydraulic system in such a way that no one component is rigidly associated with another, resulting in the propagation of vibration, and consequently noise.

Table of summary MODUL 2/3

	5.5 - 7.5 kW	11 - 22	30	37 - 45	55 - 90	110 - 200	250 - 400
	7.5 - 10.2 Hp	15 - 30 Hp	40.80 Hp	50.32 - 61.2 Hp	75 - 125 Hp	150 - 272 Hp	340 - 544 Hp
	Size 225 - D.450	Size 160/180 D.350	Size 200 - D.350	Size 225 - D.450	Size 250/280 D.550	Size 315 - D.660	Size 355/400 D.800
MODUL 2	<p>AR*</p> <p>BMT300 BMT350</p> <p>FR1*</p> <p>Kit of assembly KVG5 (Q.ty 1) + Kit of assembly KVG1 (Q.ty 1)</p>						
	<p>AD*</p> <p>BMT350 BMT400 BMT450</p> <p>FP5 FP6 FP7</p> <p>Kit of assembly KVG5/7 (Q.ty 2)</p>						
MODUL 3	<p>BMT550 BMT660 BMT800</p> <p>FP6 FP7 (BAD800 ONLY FP7)</p> <p>Kit of assembly KVG6/7 (Q.ty 1)</p>						
	5.5 - 7.5 kW	11 - 22	30	37 - 45	55 - 90	110 - 200	250 - 400
7.5 - 10.2 Hp	15 - 30 Hp	40.80 Hp	50.32 - 61.2 Hp	75 - 125 Hp	150 - 272 Hp	340 - 544 Hp	340 - 544 Hp
Size 225 - D.450	Size 160/180 D.350	Size 200 - D.350	Size 225 - D.450	Size 250/280 D.550	Size 315 - D.660	Size 355/400 D.800	Size 355/400 D.800

Motors base

BMC series

The motors base of the **BMC** series are derived from standard LMC monobloc bell-housings, and used as bases to which flanges of the **FR/FP5/FP6** series can be fitted either to increase the height of the bell-housing or to allow machining of the pump interface, not possible with a standard monobloc housing.

Motor base for installation of auxiliary flange FR1

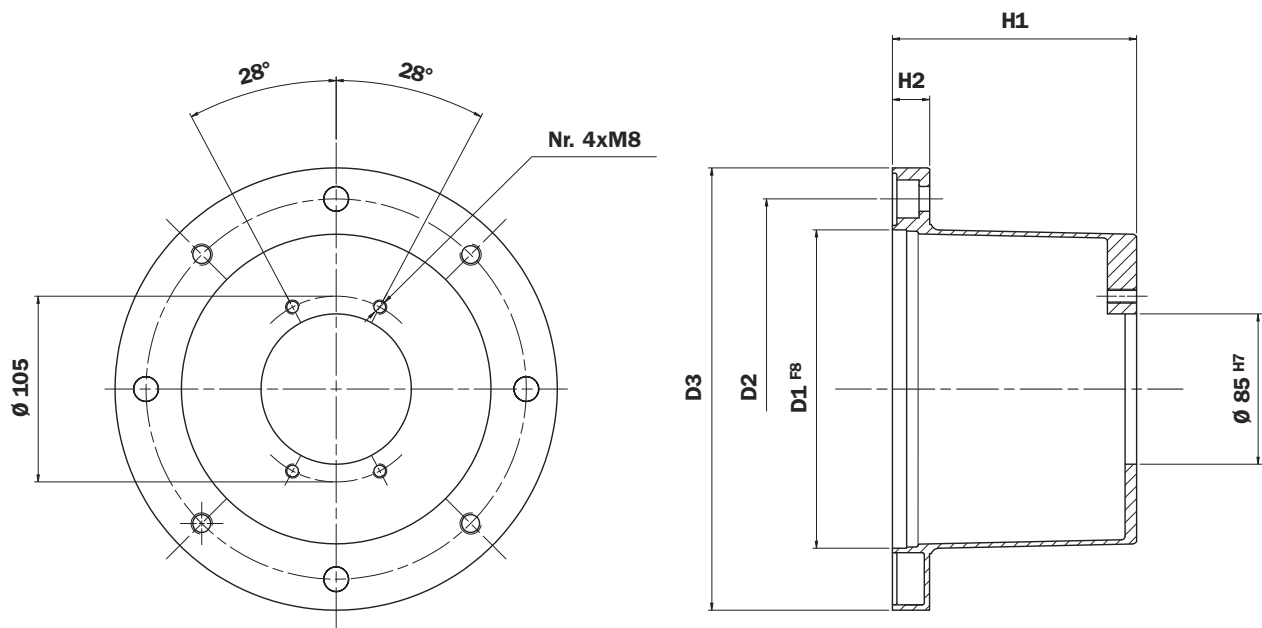

TABLE 6

Electric motor, 4-pole, 1500 rpm				Dimensions of BMC motor base							
Frame size	kW	Hp	Shaft	Motor base code	Foot bracket code	D1	D2	D3	H1	H2	Weight (kg)
80	0.53-0.75	0.75-1	19x40	BMC200A1001	PDM A 200	130	165	200	100	18	0,75
90	1.1-1.5	1.5-2	24x50	BMC200A1251	PDM A 200	130	165	200	125	18	0,95
100-112	2.2-4	3-12.5	28x60	BMC250A1141	PDM A 250	180	215	250	114	19	1,60
				BMC250A1361	PDM A 250	180	215	250	136	19	1,60
132	5.5-7.5	7.5-12.5	38x80	BMC300A1551	PDM A 300	230	265	300	155	23	3,30

Assembly kit code (motor base + flange): **KVG1**

For dimension see page 55

• For pump flange codes, see page 17

Motor base for installation of auxiliary flange FP5

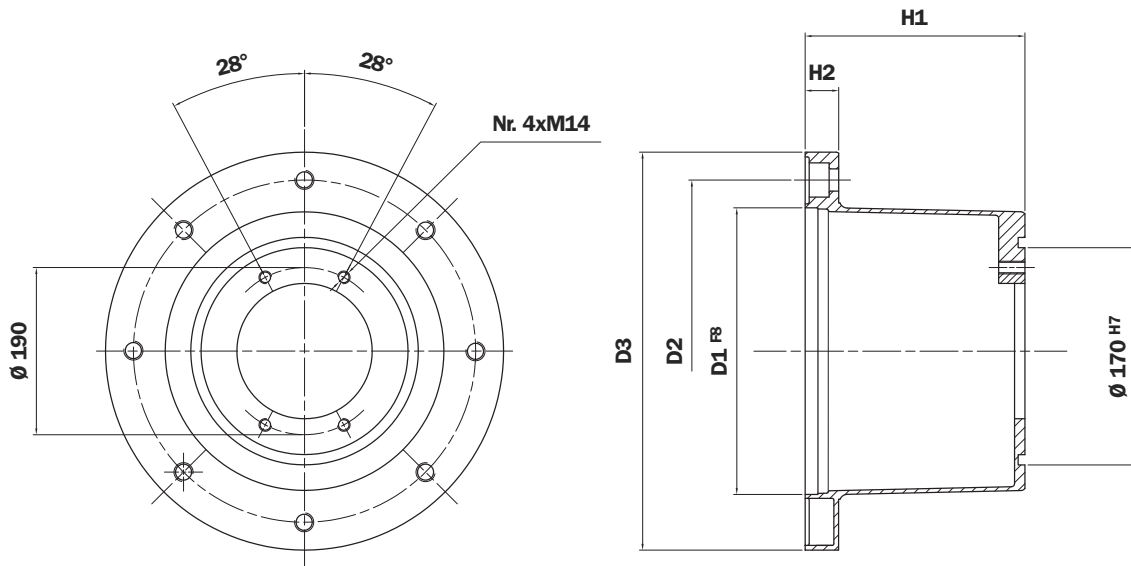

TABLE 7

Electric motor, 4-pole, 1500 rpm				Dimensions of BMC motor base							
Frame size	kW	Hp	Shaft	Motor base code	Foot bracket code	D1	D2	D3	H1	H2	Weight (kg)
132	5.5-7.5	7.5-12.5	38x80	BMC300A1555	PDM A 300	230	265	300	155	23	3,30
				BMC300A1705	PDM A 300	230	265	300	170	23	
160	11-15	15-20	42x110	BMC350A1945	PDM A 350	250	300	350	194	31	4,90
180	18.5-22	25-30	48x110								

Assembly kit code (motor base + flange): **KVG5**

- For pump flange codes, see page 17

For dimension see page 55

Motor base for installation of auxiliary flange FP6

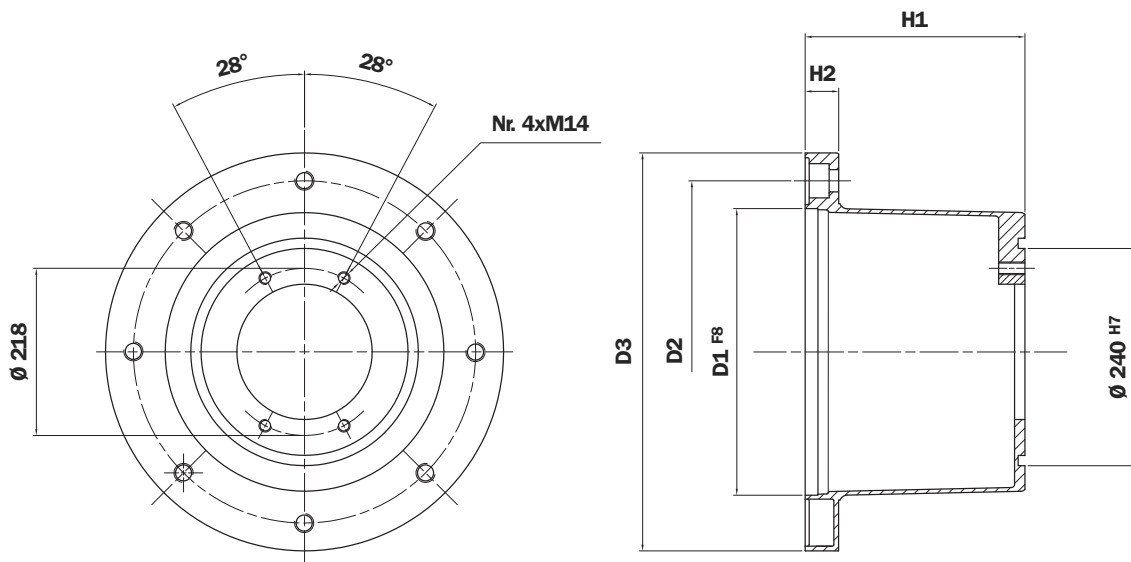

TABLE 8

Electric motor, 4-pole, 1500 rpm				Dimensions of BMC motor base							
Frame size	kW	Hp	Shaft	Motor base code	Foot bracket code	D1	D2	D3	H1	H2	Weight (kg)
160	11-15	15-20	42x110	BMC350A1946	PDM A 350	250	300	350	194	31	4,90
180	18.5-22	25-30	48x110								
200	30	40	55x140	BMC400A2016	/	300	350	400	201	31	6,90

Assembly kit code (motor base + flange): **KVG6**

- For pump flange codes, see page 17

For dimension see page 55

Pump flange

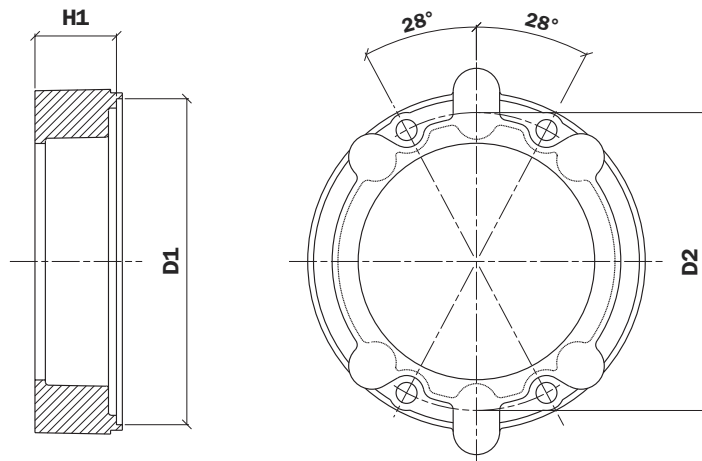

TABLE 10

Code	Flange			Assembly kit	Possible pump interfaces	Weight (kg)
	H1	D1	D2			
FR1023***	23	85	105	KVG1	S024 S025 D042 S061 S063 S083 S023 S070 S071 S072 S075 S125 S154	0,25
FR1025***	25				S021 S026 S068 S069 S080 S082 S115 S237	0,30
FR1033***	33				S021 S023 S026 S027 S070 S071 S072 S074 S080 S082 F260	0,80
FR1035***	35				S060 S063 S065	0,90
FR1040***	40				S098 S227	1,10
FR1079***	79				S031 S116	1,30

Complete the order designation with the pump interface code: Ex. **FP5026S023**

TABLE 11

Code	Flange			Assembly kit	Possible pump interfaces	Weight (kg)			
	H1	D1	D2						
FP5026***	26	190	170	KVG5	S023-S024-S025-S033-D042-S063-S070-S072-S075-S154-S254	1,00			
FP5032***	32				S024-S031-S158-S096-S125	1,10			
FP5035***	35				S021-S023-S024-S025-S026-S031-S059-S060-S068-S072-S074-S075-S083-S097-S106-S125-S131-S138	0,90			
FP5045***	45				S021-S024-S025-S026-S060-S068-S070-S071-S072-S074-S075-S106-S125-S141	0,90			
FP5056***	56				S021-S026-S072	1,61			
FP5063***	63				S021-S025-S068-S070-S079-S138-S141	1,70			
FP5064***	64				S024-S025-S059-S093-S099-S100-S104	1,70			
FP5091***	91				S025-S031-S033-S100-S113-S115-S116-S267	2,20			
FP6032***	32				240	218	KVG6	S021-S035-S081-S082	1,80
FP6045***	45	S021-S025-S026-S027-S069-S070-S075-S077-S080-S081-S082-S125-S198-S207-S215-S253	2,10						
FP6058***	58	S024-S025-S026-S027-S038-S077-S078-S079-S080-S081-S082-S207-S215-S237	2,40						
FP6070***	70	S080-S270	3,00						
FP6082***	82	S038-S080-S081-S116-S141-S198-S215	3,30						
FP6086***	86	S021-S026-S027-S077-S078-S090-S092-S166-S091-S114-S132-S198-S200	3,40						
FP6101***	101	S027-S035-S113-S115-S132-S148-S176-S228	4,20						
FP6110***	110	S080-S111	5,50						
FP7052***	52	288	258	KVG7				S028-S092-S108-S112-S133-S192	4,10
FP7066***	66							S090-S092-S166	4,75
FP7069***	69				S108-S143-S148-S158-S192-S19-S201-S204-S281-S282-S288	4,90			
FP7086***	86				S022-S027-S028-S091-S092-S108-S112-S117-S166-S184-S192-S201-S228-S300	5,20			
FP7111***	111				S028-S091-S112-S117-S144-S145-S184	6,30			
FP7124***	124				S190-S211	7,50			

A guide to select the correct bell-housing and drive coupling components

DATA REQUIRED

Electric motor power/motor size
 Manufacturer and pump type

TO VERIFY:

- 1 - Pump and motor shaft dimensions (see page 69)
- 2 - Shaft and flange pump (see pump data sheet)

Example:

- Electric motor 2 kW - 4 poles - Motor size 110/112
- Atos pump code PFE31 - Shaft 1

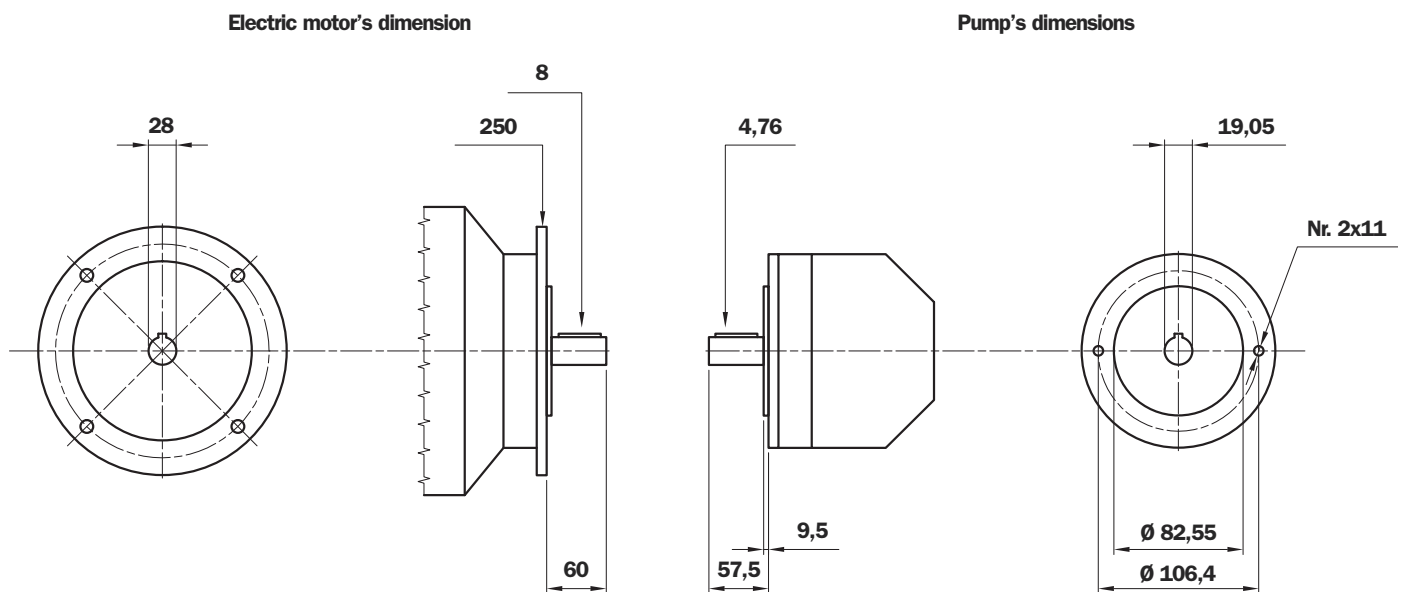

Bell-Housing's length calculation

- $H = 60 + 18 + 57,5 = 135,5$ mm (18= Sp spider - see page 49)
- Choose type of bell-housing (LMC - LMS)
 - For LMC see tab. 3 at page 11
 - For LMS see tab. 21 at page 32
 - For MODUL 2/3 see at page 36

Note: The length of bell-housing must be \geq than the length calculated (135,5 mm)

Case A - solution with LMC bell-housing

Tab. 3 at page 11 - for electric motor 2kW LMC 250
 LMC 250 bell-housing with height $\geq 135,5$ - LMC250AFSQ

- The bell-housing code must be completed with drilling pump code (see tab. 34 at page 47)
 For the specific case C= 101,6 - Nr. 2 holes M10: Code drilling 070
- Definitive bell-housing code **LMC250AFSQ070**

Case B - solution with LMS bell-housing

Tab. 21 at page 32 - for electric motor 2kW LMS 250
 LMS 250 bell-housing with height $\geq 135,5$ - LMS250AFSQ

- The bell-housing code must be completed with drilling pump code (see tab. 34 at page 47)
 For the specific case C= 101,6 - Nr. 2 holes M10: Code for. 070
- Definitive bell-housing code **LMS250AFSQ070**

Choose coupling

- **Motor half-coupling** (see tab. 37 at page 50)
 - For electric motor GR 100/112, the half-coupling is **SGEA21M05060**
- **Spider** (see tab. 35 - 36 at page 49)
 - For SGEA21, EGE2 - EGE2RR
(choose spider material on the base of the application, oil, temperature and cycle machine, etc.)
- **Pump half-coupling**
 - Choose the drilling code tab. 43 - 44 at page 53 for shaft 19,05 - Ch. 4,76 - code: **G01**
 - Half-coupling length = L BH length - THK Spider - THK Spigot
 $138 \text{ mm} - 60 - 18 - 9,5 = 50,5 \text{ mm}$
 - Choose the half-coupling's length on tab. 38 at page 50 $\leq 50,5 \text{ mm}$.
 - Available length for SGEA21= 50 mm
 - Code half-coupling code: **SGEA21G01050**

**Software for automatic calculation available on the web site
www.mpfiltri.com - tools - software**

AKM0320068

Manufacturer: ATOS
Pump type: PFE
Pump model: PFE31 Shaft 1

N. Pole: 2P
Type: M3-B5
Size: 100-112
Sec: 3-4
Isp: 4-5,44

HYDRAULIC PUMP - Technical Data

L: 57.5
d: 19.05
Ch: 4.76
E: 9.5
H: 82.55
B: 106
W: 2
F: M20

ELECTRIC MOTOR - Technical Data

L: 60
H: 28
Fig: 256
Ch: 8

Coupling material: Aluminium Cast iron Allow alternative material

Result

Coupling: M01 - 21066
Drilling Pump: 5000
Pump Shaft: G01
Motor Shaft: M05

Result

Monobloc Bellhousing:
Modular Bellhousing:
Silenced Bellhousing:

Monobloc Bellhousing:
Pump half-coupling with grub screw
For other solution please contact technical department

Modular Bellhousing: OK
Silenced Bellhousing: OK

[CLICK HERE TO PROCEED](#)

Note: For multi pumps we recommend to use a specific support on the base of the pump's dimensions and weight.

Half-coupling SGE*** series

The half-couplings series SGE*** allow secure transmission between the electric motor and the driven side; they are able to absorb shocks and vibration, in addition to compensating radial misalignment, angular and axial.

The assembly of the couplings can be horizontal/vertical, withstanding vibration and load reversals.

The complete range of couplings are extrapolated from the on-line software, with a length equal than the shaft on which must be mounted and they are completed with grub screw for fixing located on the key.

Available for cylindrical shaft with metric and imperial dimensions as well for splined shafts as per specification DIN, ISO and SAE.

Admissible misalignment radial, angular and axial

Max admissible radial misalignment

Half coupling	R (mm)
SGE * 01	0,5
SGE * 21	1,0
SGE * 31	1,0
SGE * 40	1,0
SGE * 51	1,5
SGE * 60	1,5
SGE * 80	2,0
SGE * 90	2,0

Max admissible angular misalignment

Half coupling	β (°)
SGE * 01	
SGE * 21	
SGE * 31	
SGE * 40	1,5°
SGE * 51	
SGE * 60	
SGE * 80	
SGE * 90	

Max admissible angular misalignment

Half coupling	A (mm)
SGE * 01	2,0
SGE * 21	2,5
SGE * 31	3,0
SGE * 40	3,5
SGE * 51	3,5
SGE * 60	3,5
SGE * 80	4,0
SGE * 90	5,0

Normative ATEX 94/9/CE

Half-couplings SGE*** series are available to use in hazardous area.

The couplings are certified according to ATEX 94/9/CE (ATEX 95).

Category certified 2G - area 1 and 2.

Other information available on our web site "www.mpfiltri.com".

MP Filtri couplings are developed with:

CAD 3D



FEM (calculation)



Drawings 3D available on website www.mpfiltri.com at section TOOLS/2D-3D COMPONENTS

The half-couplings SGE*** series are in conformity to normative **DIN 740/2**.
The max torque to transmit is always less than the max torque that the coupling can transmit.

Examples verification of the coupling

Torque transmitted by electric motor:

Mt: $9560 \times \text{kW} / \text{rpm} = \text{Nm}$

Me > $\text{Mt} \times \text{S} = \text{Nm}$

Where:

Mt: Torque transmitted by electric motor

Me: Torque transmitted by coupling (see table 14)

kW: Power of electric motor

Rpm: Revolutions per minute of electric motor

S: Service factor (see table 14)

TABLE 1

Small pumps, uniform load, low operating pressures e.g. rotary action machine tools - 5/8 work cycles per hour	1.3
Small pumps, uniform load, high working pressures e.g. lifting equipment - 120-150 work cycles per hour	1.5
Pumps, non-uniform load e.g. lifting equipment - 280-300 work cycles per hour	1.7

Example

Electric motor, 4 pole - 4 kW

hydraulic pump, uniform load, low operating pressure

Mt: $9560 \times 4 / 1500 = 25.45 \text{ Nm}$

Me > $25.49 \times 1.3 = 33 \text{ Nm}$

Half-coupling SGEA21 meets the above requirement.

Select the half-coupling of the calculated size from the motor half-couplings table.

Note: When selecting the coupling, remember that for pumps with splined shaft, only cast iron couplings of the SGEG series can be used.

Determine the size of the coupling according to the type of installation and application envisaged, on the basis of the following formulas and tables:

TABLE 2

Half-coupling type	External diameter mm	Nominal torque Me - Nm	Maximum transmissible torque Me - Nm	
ALUMINIUM	SGEA01	43	15	20
	SGEA21	68	160	190
	SGEA31	85	340	380
	SGEA51	109,5	550	620
CAST IRON	SGEG01	40	20	30
	SGEG30	80	400	450
	SGEG40	95	550	620
	SGEG60	120	760	850
	SGEG80	160	2200	2500
	SGEG90	200	5500	6100
STEEL	SGES40	95	550	620
	SGES60	120	760	850
	SGES80	160	2200	2500

Nominal and maximum torque values are referred to couplings assembled with standard flexible spiders of the **EGE**** series (see page 49).

Where higher torques are to be transmitted, use flexible spiders of the **EGE**RR** series (see page 49).

Noise

Noise is a particularly pervasive problem so much so that there have been statutory regulations in place now for some years, designed to limit harmful occupational exposure. Many of the machines used in industry today are equipped with oil-hydraulic systems, which happen to be a major source of noise.

1. Theory and definition of noise

From a health and hygiene standpoint, noise can be defined as an unpleasant and undesirable sound, or an unpleasant and annoying or intolerable auditory sensation (noise being any sound phenomena that may be accompanied by sensations of disturbance and pain). By definition, acoustic phenomena are oscillatory in character, propagated in a flexible medium and causing pressure variations at the points, and the areas adjacent to those points, through which they pass.

2. Sound

Technically considered, certain elements must be present simultaneously for acoustic phenomena to occur:

- Sound source
- Transmission medium
- Receiver

Motor and pump unit

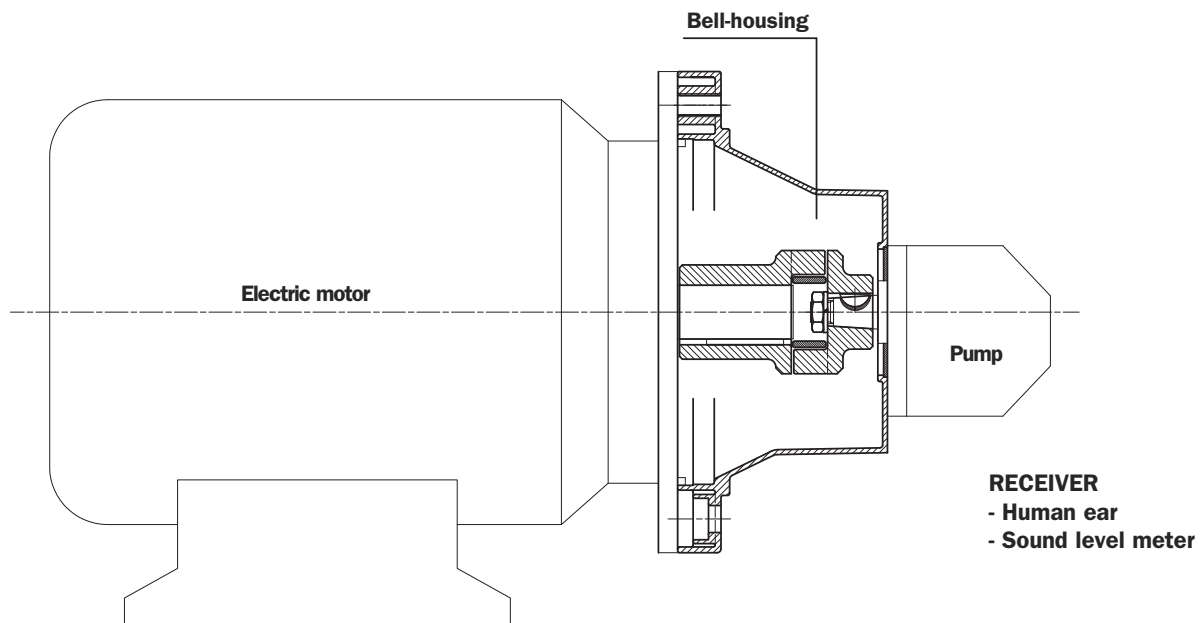

The **electric motor** and the **pump**, together with the drive coupling, are the **SOURCE OF THE NOISE**.

The **Bell-housing** is the noise transmission medium.

Depending on whether the monobloc bell-housing is a rigid or low noise type, there will be variations in the flexible properties of the transmission medium.

The acoustic phenomena are dissimilar in the two cases, given the differences in pressure variation and particle displacement.

Assembly of motor and pump unit

As mentioned in the presentation, low noise bell-housing will help to attenuate the transmission of vibrations and the emission of noise generated by the system.

Self-evidently, however, the mere adoption of a low noise bell-housing will achieve little unless the motor and pump are correctly installed on the machine, or on the tank of the hydraulic power unit.

- Should be followed in order to achieve best possible results and correct installation:

1. Motor and pump unit mounted horizontally on oil tank lid

- The suction pipe attached to the pump must be rigid, and fitted using a resilient bulkhead flange of the FTA series, which helps to cushion the vibrations propagated between the pipe and the tank lid. If pipes need to be bent, the radius of curvature must be at least 3 times the pipe diameter. Do not use elbow fittings, as these will significantly increase pressure losses.
- The pressure pipeline of the pump must be flexible, and long enough to include bends with the minimum radius of curvature recommended by the manufacturer for the specified operating pressure.
- The return pipeline running from the service to the filter must be flexible. Where oil is returned directly to the tank of the hydraulic power unit through a rigid pipe, it is advisable to use a resilient bulkhead flange of the FTR series, which helps to cushion the vibrations propagated between the pipe and the tank lid.
- Anti-vibration devices (resilient mounts or damping rods) must be located under the feet of the electric motor or the PDM foot brackets, depending on the mounting position of the motor.
- The lids of hydraulic oil tanks must be sturdy enough to support the load they carry.

2. Motor and pump unit mounted horizontally on machine

- As a matter of good practice, the oil tank and motor-pump unit should be mounted on a single supporting frame of strength sufficient to support the load.
- If the hydraulic system is fitted with a side-mounted filter, the suction pipeline to the pump must be flexible, and long enough to include bends with the minimum radius of curvature recommended by the manufacturer.
- If the suction filter is not side mounted, the pipeline should be rigid and installed in conjunction with a compensating coupling.
- The pressure pipeline of the pump must be flexible, and long enough to include bends with the minimum radius of curvature recommended by the manufacturer for the specified operating pressure.
- The return pipeline running from the service to the filter must be flexible. Where oil is returned directly to the tank of the hydraulic power unit through a rigid pipe, it is advisable to use a resilient bulkhead flange of the FTR series, which helps to cushion the vibrations propagated between the pipe and the tank lid.
- Anti-vibration devices (resilient mounts or damping rods) must be located under the feet of the electric motor or the PDM foot brackets, depending on the mounting position of the motor.

Note: The above guidelines are indicative only, and subordinate to the solutions adopted ultimately by design engineers.

In conclusion: For best results, in any event, the motor-and-pump unit should be incorporated into the hydraulic system in such a way that no one component is rigidly associated with another, resulting in the propagation of vibration, and consequently noise.

Table of summary MODUL 2/3

	5.5 - 7.5 kW	11 - 22	30	37 - 45	55 - 90	110 - 200	250 - 400
	7.5 - 10.2 Hp	15 - 30 Hp	40.80 Hp	50.32 - 61.2 Hp	75 - 125 Hp	150 - 272 Hp	340 - 544 Hp
	Size 225 - D.450	Size 160/180 D.350	Size 200 - D.350	Size 225 - D.450	Size 250/280 D.550	Size 315 - D.660	Size 355/400 D.800
MODUL 2	<p>AR*</p> <p>BMT300 BMT350</p> <p>FR1*</p> <p>Kit of assembly KVG5 (Q.ty 1) + Kit of assembly KVG1 (Q.ty 1)</p>						
	<p>AD*</p> <p>BMT350 BMT400 BMT450</p> <p>FP5 FP6 FP7</p> <p>Kit of assembly KVG5/7 (Q.ty 2)</p>						
MODUL 3	<p>Kit of assembly KVG6/7 (Q.ty 1)</p> <p>BMT550 BMT660 BMT800</p> <p>FP6 FP7 (BAD800 ONLY FP7)</p>						
	5.5 - 7.5 kW	11 - 22	30	37 - 45	55 - 90	110 - 200	250 - 400
7.5 - 10.2 Hp	15 - 30 Hp	40.80 Hp	50.32 - 61.2 Hp	75 - 125 Hp	150 - 272 Hp	340 - 544 Hp	
Size 225 - D.450	Size 160/180 D.350	Size 200 - D.350	Size 225 - D.450	Size 250/280 D.550	Size 315 - D.660	Size 355/400 D.800	

Monobloc bell-housings

LMC series

LMC series monobloc bell-housings are used as connecting elements between **B3 - B5** flanged **UNEL-MEC** electric motors and a wide range of hydraulic pumps available on the international market.

With special machining, they can be modified to serve as motors base that will accept standard flanges manufactured by **MP Filtri S.P.A.** (MODUL-2).

Thanks to their considerable versatility and to the extensive range of pump flanges available, **LMC** series monobloc bell-housings are compatible with electric motors from **size 80, rated 0.5 kW**, up to **size 225, rated 37/45 kW**, and therefore suitable for most applications.

Technical specifications

LMC

Materials

- **Monobloc bell-housing**
Pressure diecast aluminium alloy.
- **Pump flange**
Pressure diecast aluminium alloy.
- **Foot bracket**
Pressure diecast aluminium alloy.

Temperature

- $-30^{\circ}\text{C} \div +80^{\circ}\text{C}$
For temperatures outside this range, consult the MP Filtri Technical and Sales Department.

Compatibility with fluids

- **Monobloc bell-housings compatible for use with:**

Mineral oils

Types HH-HL-HM-HR-HV-HG, to ISO 6743/4 standard

Water based emulsions

Types HFAE - HFAS, to ISO 6743/4 standard

Water glycol

Type HFC, to ISO 6743/4 standard

Ask for anodized version



Special Applications

- **Any applications not covered by the normal indications contained in this catalogue must be evaluated and approved by the MP Filtri Technical and Sales Department**

Monobloc bell-housing

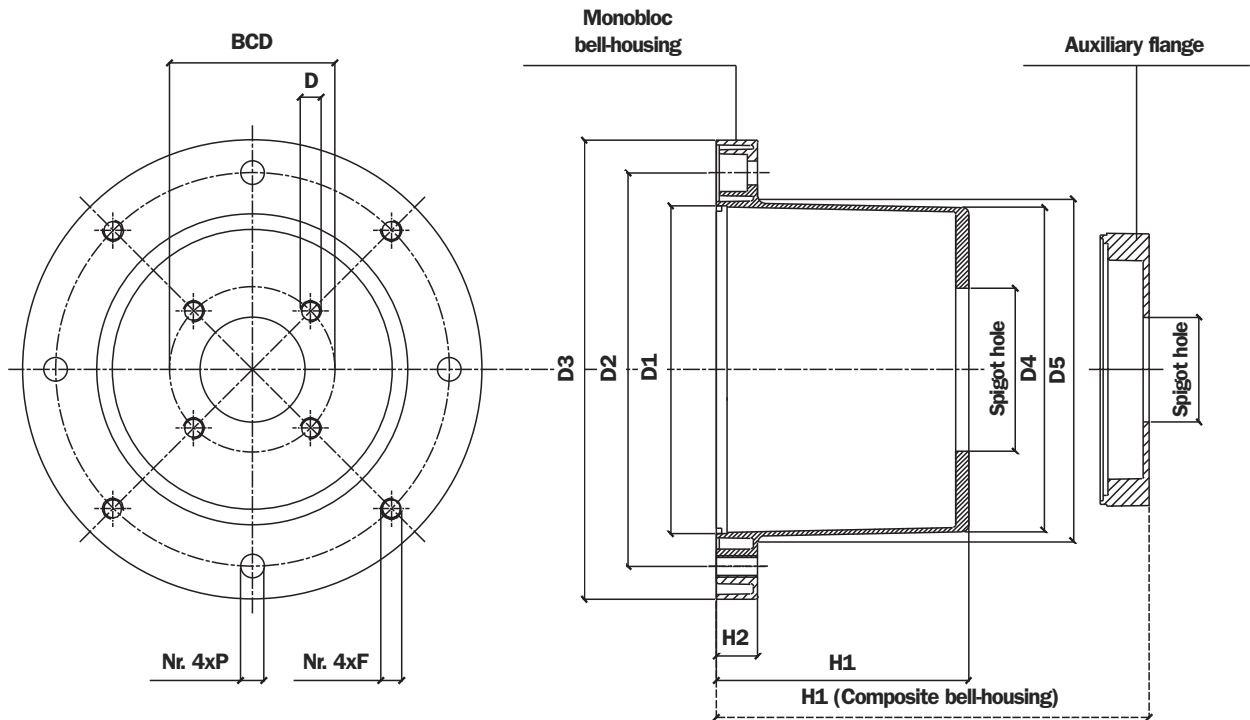

The auxiliary flange, if specified, is supplied already fitted to the bell-housing (MODUL-2).

- For loose components see pages 15 - 16 - 17
- Check that the pump interface dimensions are compatible with those of the bell-housing

Note: The hole made in the tank cover should be 2 mm larger than dimension D5

Machining tolerances

D1	F8
Spigot hole	H7
H1	± 0,15 mm

Concentricity of D1/Spigot hole

LMC 200 - LMC 350	0,20 mm
LMC 300 - LMC 450	0,25 mm

TABLE 3

Electric motor, 4-pole, 1500 rpm				Dimensions of LMC monobloc bell housing										
Frame size	kW	Hp	Shaft	Bell-housing code	Foot bracket code	D1	D2	D3	D4	D5	H1	H2	F	P
80	0.53-0.75	0.75-1	19x40	LMC 200	PDM A 200	130	165	200	125	135		18	M10	11
90	1.1-1.5	1.5-2	24x50	LMC 200	PDM A 200	130	165	200	125	135		18	M10	11
100-112	2.2-4	3-5.5	28x60	LMC 250	PDM A 250	180	215	250	175	186		19	M12	14
132	5.5-7.5	7.5-12.5	38x80	LMC 300	PDM A 300	230	265	300	230	235		23	M12	14
160	11-15	15-20	42x110	LMC 350	PDM A 350	250	300	350	240	254		31	M16	18
180	18.5-22	25-30	48x110	LMC 350	PDM A 350	250	300	350	240	254		31	M16	18
200	37	45	55x140	LMC 400	/	300	350	400	280	305		31	M16	-
225	37-45	50-60	60x140	LMC 450	/	350	400	450	320	350		31	M16	-
					For dimension see page 55						See Tab. 4 - 5			

To determine dimension H1 of the bell-housing
For dimensions of the foot bracket

see table 12
see page 55

LMC bell-housing, dimension H1

TABLE 4

Monobloc bell-housing		
Code	H1	Weight (kg)
LMC200AFSJ***	100	0,75
LMC200AFSW***	125	0,95
LMC250AFSM***	114	1,50
LMC250AFSQ***	138	1,60
LMC250AFSR***	159	1,75
LMC300AFST***	155	3,20
LMC300AFSX***	170	3,30
LMC350AFSY***	178	4,80
LMC350AFSU***	194	4,90
LMC400AFSV***	201	6,50
LMC450AFSZ***	250	9,00

TABLE 5a

Modul 2 bell-housing		
Code	H1	Weight (kg)
LMC200AFRB***	125	1,85
LMC200AFRC***	133	1,95
LMC200AFRD***	158	2,10
LMC250AFRB***	156	2,50
LMC250AFRC***	161	2,75
LMC250AFRA***	185	4,20
LMC300AFRB***	191	4,45
LMC300AFRC***	193	4,60
LMC300AFRD***	201	4,95
LMC300AF5A***	192	4,50
LMC300AF5B***	198	4,80

TABLE 5b

Modul 2 bell-housing		
Code	H1	Weight (kg)
LMC350AF5A***	218	5,90
LMC350AF5B***	224	6,15
LMC350AF6A***	239	6,80
LMC350AF6B***	252	7,30
LMC400AF5A***	228	7,50
LMC400AF5B***	234	7,90
LMC400AF6A***	247	8,50
LMC400AF6B***	260	9,00
LMC450AF5A***	226	10,00
LMC450AF5B***	234	10,40
LMC450AF6A***	295	11,20
LMC450AF6B***	308	11,60

Note: The three asterisks in the designation code represent the three digits identifying the pump interface (see page 47).

Specified tightening torques for auxiliary flange

- FR* 18 Nm
- F5* 100 Nm
- F6* 180 Nm

Recommended tightening torques for motor/pump assembly bolts

- M6 10 Nm
- M8 24 Nm
- M10 50 Nm
- M12 84 Nm
- M14 135 Nm
- M16 205 Nm
- M18 280 Nm
- M20 400 Nm
- M22 530 Nm
- M24 690 Nm

These values are calculated to exploit the performance of the bolt at 70% of its elastic limit.

This means in practice that the shank of the bolt will be stressed typically to 60-70% of its limit of elasticity in the course of being tightened.

The values indicated are valid for hexagon head bolts to UNI 5737 and hexagon socket screws to UNI 5931, property class 8.8, tightened by degrees using a torque wrench.

If bolts or screws are tightened using impact or hammer action drivers, the applied torque should be reduced by 10%.

Comparative table

MP Filtri		OMT	Hydrapp	Raja	KTR
New code	Old code	code	code	code	code
LMC200A***	LMB200A100***	TH20A***	/	R200/99-115/...	PK200/3/...
LMC200A***	/	TH1***	HLC1	R200/120-135/...	PL200/8/...
LMC250A***	LMB250A109***	TH2***	HLC3	R250/120-135/...	PL250/6/...
LMC300A***	LMB300A130***	TH3***	HLC5	R300/155-170/...	PL300/4/...
LMC350A***	LMB350A179***	TH4***	HLC8	R350/173-194/...	PK350/4/...
LMC400A***	/	TH15***	HLC12	R400/194-210/...	PK400/4/...
LMC450A***	/	TH18***	/	R450/250-210/...	PK450/4/...

A guide to select the correct bell-housing and drive coupling components

DATA REQUIRED

Electric motor power/motor size
 Manufacturer and pump type

TO VERIFY:

- 1 - Pump and motor shaft dimensions (see page 69)
- 2 - Shaft and flange pump (see pump data sheet)

Example:

- Electric motor 2 kW - 4 poles - Motor size 110/112
- Atos pump code PFE31 - Shaft 1

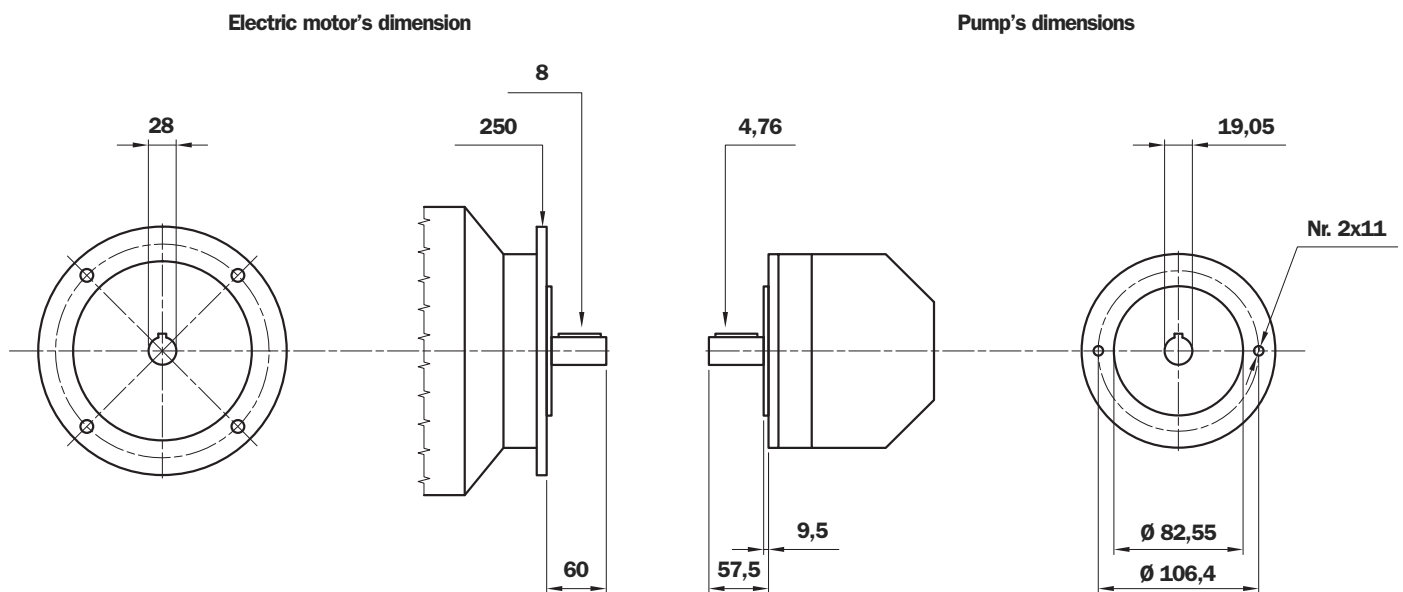

Bell-Housing's length calculation

- $H = 60 + 18 + 57,5 = 135,5$ mm (18= Sp spider - see page 49)
- Choose type of bell-housing (LMC - LMS)
 - For LMC see tab. 3 at page 11
 - For LMS see tab. 21 at page 32
 - For MODUL 2/3 see at page 36

Note: The length of bell-housing must be \geq than the length calculated (135,5 mm)

Case A - solution with LMC bell-housing

Tab. 3 at page 11 - for electric motor 2kW LMC 250
 LMC 250 bell-housing with height $\geq 135,5$ - LMC250AFSQ

- The bell-housing code must be completed with drilling pump code (see tab. 34 at page 47)
 For the specific case C= 101,6 - Nr. 2 holes M10: Code drilling 070
- Definitive bell-housing code **LMC250AFSQ070**

Case B - solution with LMS bell-housing

Tab. 21 at page 32 - for electric motor 2kW LMS 250
 LMS 250 bell-housing with height $\geq 135,5$ - LMS250AFSQ

- The bell-housing code must be completed with drilling pump code (see tab. 34 at page 47)
 For the specific case C= 101,6 - Nr. 2 holes M10: Code for. 070
- Definitive bell-housing code **LMS250AFSQ070**

Choose coupling

- **Motor half-coupling** (see tab. 37 at page 50)
 - For electric motor GR 100/112, the half-coupling is **SGEA21M05060**
- **Spider** (see tab. 35 - 36 at page 49)
 - For SGEA21, EGE2 - EGE2RR
(choose spider material on the base of the application, oil, temperature and cycle machine, etc.)
- **Pump half-coupling**
 - Choose the drilling code tab. 43 - 44 at page 53 for shaft 19,05 - Ch. 4,76 - code: **G01**
 - Half-coupling length = L BH length - THK Spider - THK Spigot
 $138 \text{ mm} - 60 - 18 - 9,5 = 50,5 \text{ mm}$
 - Choose the half-coupling's length on tab. 38 at page 50 $\leq 50,5 \text{ mm}$.
 - Availabe length for SGEA21= 50 mm
 - Code half-coupling code: **SGEA21G01050**

**Software for automatic calculation available on the web site
www.mpfiltri.com - tools - software**

The screenshot shows the MP Filtri software interface for pump and motor selection. The interface is divided into several sections:

- HYDRAULIC PUMP - Technical Data:**
 - AKA: AKM0320068
 - Manufacturer: ATOS
 - Pump type: PFE
 - Pump model: PFE31 Shaft 1
 - Technical Data: L1: 57.5, d1: 19.05, Ch1: 4.76, E: 9.5, Pd: 82.55, Bd: 106, Wc: 2, F: M20
- ELECTRIC MOTOR - Technical Data:**
 - N. Pole: 2P
 - Type: M3-B5
 - Size: 100-112
 - Sec: 3-4
 - tp: 4-5,44
 - Technical Data: L1: 60, H1: 28, Fig: 256, Ch: 8
- Coupling material:**
 - Aluminium
 - Cast iron
 - Allow alternative material
- Result:**
 - Coupling: M01 - 21066
 - Drilling Pump: 5000
 - Pump Shaft: G01
 - Motor Shaft: M01
 - Monobloc Bellhousing: OK
 - Modular Bellhousing: Not OK
 - Silenced Bellhousing: Not OK
 - Description: Pump half-coupling with grub screw. For other solution please contact technical department.

At the bottom left, there is a button labeled "CLICK HERE TO PROCEED".

Note: For multi pumps we recommend to use a specific support on the base of the pump's dimensions and weight.

Half-coupling SGE*** series

The half-couplings series SGE*** allow secure transmission between the electric motor and the driven side; they are able to absorb shocks and vibration, in addition to compensating radial misalignment, angular and axial.

The assembly of the couplings can be horizontal/vertical, withstanding vibration and load reversals.

The complete range of couplings are extrapolated from the on-line software, with a length equal than the shaft on which must be mounted and they are completed with grub screw for fixing located on the key.

Available for cylindrical shaft with metric and imperial dimensions as well for splined shafts as per specification DIN, ISO and SAE.

Admissible misalignment radial, angular and axial

Max admissible radial misalignment

Half coupling	R (mm)
SGE * 01	0,5
SGE * 21	1,0
SGE * 31	1,0
SGE * 40	1,0
SGE * 51	1,5
SGE * 60	1,5
SGE * 80	2,0
SGE * 90	2,0

Max admissible angular misalignment

Half coupling	β (°)
SGE * 01	
SGE * 21	
SGE * 31	
SGE * 40	1,5°
SGE * 51	
SGE * 60	
SGE * 80	
SGE * 90	

Max admissible angular misalignment

Half coupling	A (mm)
SGE * 01	2,0
SGE * 21	2,5
SGE * 31	3,0
SGE * 40	3,5
SGE * 51	3,5
SGE * 60	3,5
SGE * 80	4,0
SGE * 90	5,0

Normative ATEX 94/9/CE

Half-couplings SGE*** series are available to use in hazardous area.

The couplings are certified according to ATEX 94/9/CE (ATEX 95).

Category certified 2G - area 1 and 2.

Other information available on our web site "www.mpfiltri.com".

MP Filtri couplings are developed with:

CAD 3D



FEM (calculation)



Drawings 3D available on website www.mpfiltri.com at section TOOLS/2D-3D COMPONENTS

The half-couplings SGE*** series are in conformity to normative **DIN 740/2**.
The max torque to transmit is always less than the max torque that the coupling can transmit.

Examples verification of the coupling

Torque transmitted by electric motor:

Mt: $9560 \times \text{kW} / \text{rpm} = \text{Nm}$

Me > $\text{Mt} \times \text{S} = \text{Nm}$

Where:

Mt: Torque transmitted by electric motor

Me: Torque transmitted by coupling (see table 14)

kW: Power of electric motor

Rpm: Revolutions per minute of electric motor

S: Service factor (see table 14)

TABLE 1

Small pumps, uniform load, low operating pressures e.g. rotary action machine tools - 5/8 work cycles per hour	1.3
Small pumps, uniform load, high working pressures e.g. lifting equipment - 120-150 work cycles per hour	1.5
Pumps, non-uniform load e.g. lifting equipment - 280-300 work cycles per hour	1.7

Example

Electric motor, 4 pole - 4 kW

hydraulic pump, uniform load, low operating pressure

Mt: $9560 \times 4 / 1500 = 25.45 \text{ Nm}$

Me > $25.49 \times 1.3 = 33 \text{ Nm}$

Half-coupling SGEA21 meets the above requirement.

Select the half-coupling of the calculated size from the motor half-couplings table.

Note: When selecting the coupling, remember that for pumps with splined shaft, only cast iron couplings of the SGEG series can be used.

Determine the size of the coupling according to the type of installation and application envisaged, on the basis of the following formulas and tables:

TABLE 2

Half-coupling type	External diameter mm	Nominal torque Me - Nm	Maximum transmissible torque Me - Nm
ALUMINIUM	SGEA01	15	20
	SGEA21	160	190
	SGEA31	340	380
	SGEA51	550	620
CAST IRON	SGEG01	20	30
	SGEG30	400	450
	SGEG40	550	620
	SGEG60	760	850
	SGEG80	2200	2500
	SGEG90	5500	6100
STEEL	SGES40	550	620
	SGES60	760	850
	SGES80	2200	2500

Nominal and maximum torque values are referred to couplings assembled with standard flexible spiders of the **EGE**** series (see page 49).

Where higher torques are to be transmitted, use flexible spiders of the **EGE**RR** series (see page 49).

Noise

Noise is a particularly pervasive problem so much so that there have been statutory regulations in place now for some years, designed to limit harmful occupational exposure. Many of the machines used in industry today are equipped with oil-hydraulic systems, which happen to be a major source of noise.

1. Theory and definition of noise

From a health and hygiene standpoint, noise can be defined as an unpleasant and undesirable sound, or an unpleasant and annoying or intolerable auditory sensation (noise being any sound phenomena that may be accompanied by sensations of disturbance and pain). By definition, acoustic phenomena are oscillatory in character, propagated in a flexible medium and causing pressure variations at the points, and the areas adjacent to those points, through which they pass.

2. Sound

Technically considered, certain elements must be present simultaneously for acoustic phenomena to occur:

- Sound source
- Transmission medium
- Receiver

Motor and pump unit

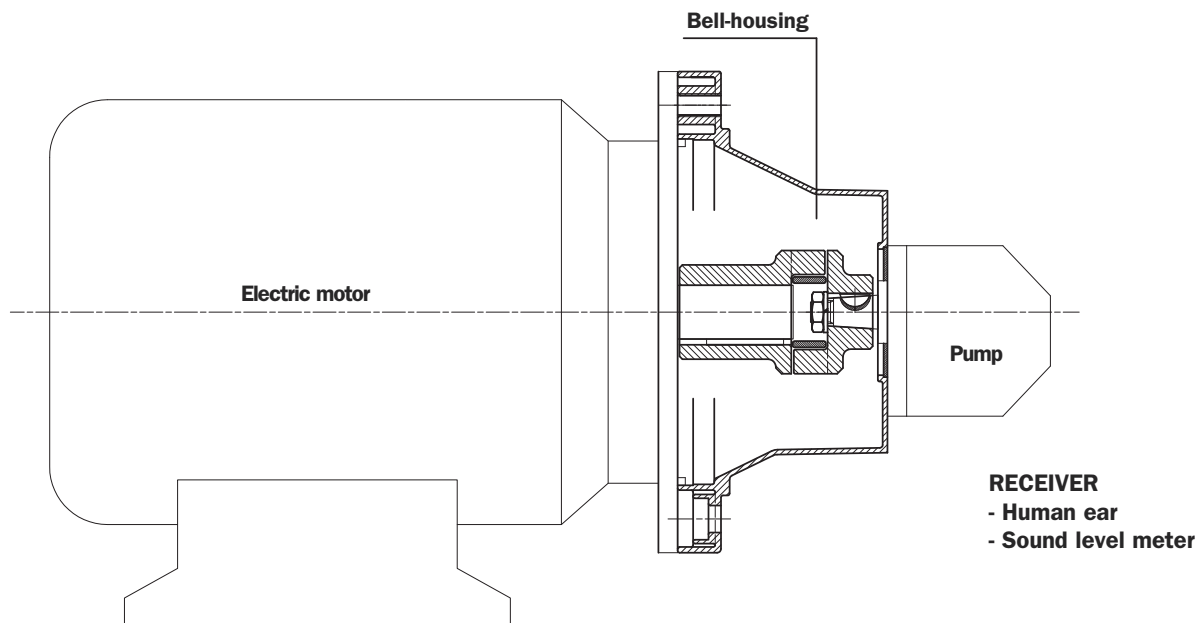

The **electric motor** and the **pump**, together with the drive coupling, are the **SOURCE OF THE NOISE**.

The **Bell-housing** is the noise transmission medium.

Depending on whether the monobloc bell-housing is a rigid or low noise type, there will be variations in the flexible properties of the transmission medium.

The acoustic phenomena are dissimilar in the two cases, given the differences in pressure variation and particle displacement.

Assembly of motor and pump unit

As mentioned in the presentation, low noise bell-housing will help to attenuate the transmission of vibrations and the emission of noise generated by the system.

Self-evidently, however, the mere adoption of a low noise bell-housing will achieve little unless the motor and pump are correctly installed on the machine, or on the tank of the hydraulic power unit.

- Should be followed in order to achieve best possible results and correct installation:

1. Motor and pump unit mounted horizontally on oil tank lid

- The suction pipe attached to the pump must be rigid, and fitted using a resilient bulkhead flange of the FTA series, which helps to cushion the vibrations propagated between the pipe and the tank lid. If pipes need to be bent, the radius of curvature must be at least 3 times the pipe diameter. Do not use elbow fittings, as these will significantly increase pressure losses.
- The pressure pipeline of the pump must be flexible, and long enough to include bends with the minimum radius of curvature recommended by the manufacturer for the specified operating pressure.
- The return pipeline running from the service to the filter must be flexible. Where oil is returned directly to the tank of the hydraulic power unit through a rigid pipe, it is advisable to use a resilient bulkhead flange of the FTR series, which helps to cushion the vibrations propagated between the pipe and the tank lid.
- Anti-vibration devices (resilient mounts or damping rods) must be located under the feet of the electric motor or the PDM foot brackets, depending on the mounting position of the motor.
- The lids of hydraulic oil tanks must be sturdy enough to support the load they carry.

2. Motor and pump unit mounted horizontally on machine

- As a matter of good practice, the oil tank and motor-pump unit should be mounted on a single supporting frame of strength sufficient to support the load.
- If the hydraulic system is fitted with a side-mounted filter, the suction pipeline to the pump must be flexible, and long enough to include bends with the minimum radius of curvature recommended by the manufacturer.
- If the suction filter is not side mounted, the pipeline should be rigid and installed in conjunction with a compensating coupling.
- The pressure pipeline of the pump must be flexible, and long enough to include bends with the minimum radius of curvature recommended by the manufacturer for the specified operating pressure.
- The return pipeline running from the service to the filter must be flexible. Where oil is returned directly to the tank of the hydraulic power unit through a rigid pipe, it is advisable to use a resilient bulkhead flange of the FTR series, which helps to cushion the vibrations propagated between the pipe and the tank lid.
- Anti-vibration devices (resilient mounts or damping rods) must be located under the feet of the electric motor or the PDM foot brackets, depending on the mounting position of the motor.

Note: The above guidelines are indicative only, and subordinate to the solutions adopted ultimately by design engineers.

In conclusion: For best results, in any event, the motor-and-pump unit should be incorporated into the hydraulic system in such a way that no one component is rigidly associated with another, resulting in the propagation of vibration, and consequently noise.

Table of summary MODUL 2/3

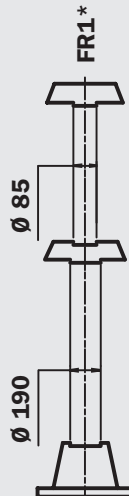
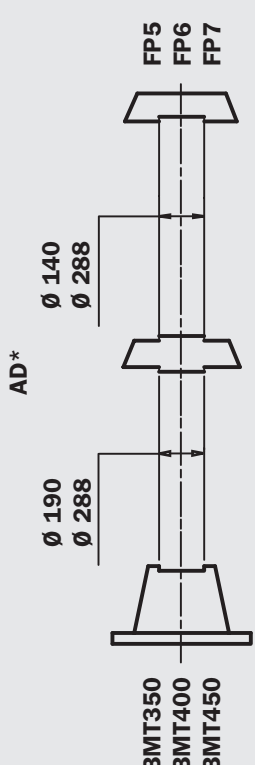
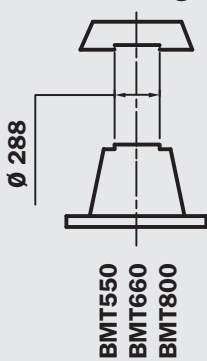
	5.5 - 7.5 kW	11 - 22	30	37 - 45	55 - 90	110 - 200	250 - 400
	7.5 - 10.2 Hp	15 - 30 Hp	40.80 Hp	50.32 - 61.2 Hp	75 - 125 Hp	150 - 272 Hp	340 - 544 Hp
	Size 225 - D.450	Size 160/180 D.350	Size 200 - D.350	Size 225 - D.450	Size 250/280 D.550	Size 315 - D.660	Size 355/400 D.800
MODUL 2	 <p>AR*</p> <p>BMT300 BMT350</p> <p>FR1*</p> <p>Ø 190</p> <p>Ø 85</p> <p>Kit of assembly KVG5 (Q.ty 1) + Kit of assembly KVG1 (Q.ty 1)</p>						
	 <p>AD*</p> <p>BMT350 BMT400 BMT450</p> <p>FP5 FP6 FP7</p> <p>Ø 190</p> <p>Ø 140</p> <p>Ø 288</p> <p>Kit of assembly KVG5/7 (Q.ty 2)</p>						
MODUL 3	 <p>BMT550 BMT660 BMT800</p> <p>FP6 FP7 (BAD800 ONLY FP7)</p> <p>Ø 288</p> <p>Kit of assembly KVG6/7 (Q.ty 1)</p>						
	5.5 - 7.5 kW	11 - 22	30	37 - 45	55 - 90	110 - 200	250 - 400
7.5 - 10.2 Hp	15 - 30 Hp	40.80 Hp	50.32 - 61.2 Hp	75 - 125 Hp	150 - 272 Hp	340 - 544 Hp	
Size 225 - D.450	Size 160/180 D.350	Size 200 - D.350	Size 225 - D.450	Size 250/280 D.550	Size 315 - D.660	Size 355/400 D.800	

Monobloc bell-housing

LMC series

LMC series monobloc bell-housings for gear pumps are used to interconnect **UNEL-MEC frame electric motors with B3 - B5 - B14** flange, and internal gear pumps with standard rectangular flange.

Accordingly, these components can be classified as standard units in terms both of the pump flange fixing holes, and of the shaft design.

Available with or without a removable centre ring, they will cover the majority of applications within a range including in electric motors from size **63** rated 0.12 kW, up to size **280** rated 75 kW.

Technical specifications

LMC

Materials

- **Monobloc bell-housing**
Pressure diecast aluminium alloy.
- **Pump flange**
Pressure diecast aluminium alloy.
- **Foot bracket**
Pressure diecast aluminium alloy.
- **Damping ring**
Vulcanized aluminium
- **Gaskets**
Special paper (guarnital).

Temperature

- $-30^{\circ}\text{C} \div +80^{\circ}\text{C}$
For temperatures outside this range,
contact the MP Filtri Technical and Sales Department.

Compatibility with fluids

- **Monobloc bell-housing compatible for use with:**
 - Mineral oils**
Types HH-LL-HM-HR-HV-HC, to ISO 6743/4 standard
 - Water based emulsions**
Types HFAE - HFAS, to ISO 6743/4 standard
 - Water glycol**
Type HFC, to ISO 6743/4 standard
- Ask for anodized version**

Special Applications

- **Any applications not covered by the normal indications contained in this catalogue must be evaluated and approved by the MP Filtri Technical and Sales Department.**



Monobloc bell-housing for gear pumps

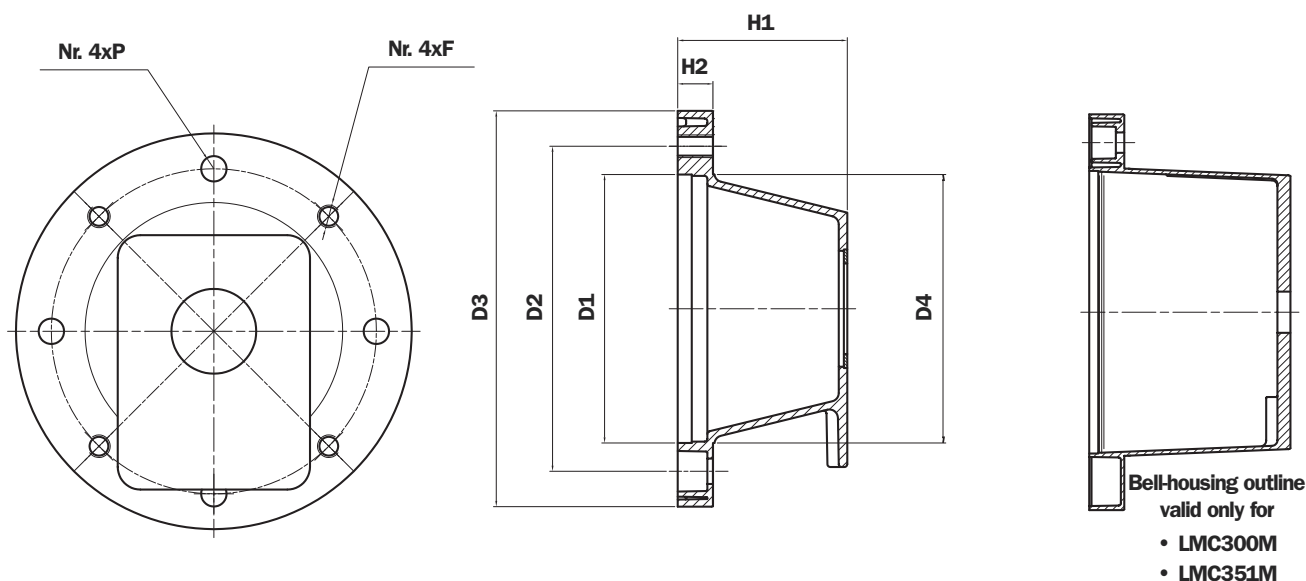

The auxiliary flange, if specified, is supplied already fitted to the bell-housing (MODUL-2).

Note: The hole made in the tank cover should be 2 mm larger than dimension D4

Machining tolerances

D1	F8
Spigot hole	H7
H1	± 0,15 mm

Concentricity of D1/Spigot hole

LMC 090 - LMC 160	0,15 mm
LMC 200 - LMC 350	0,20 mm
LMC 300 - LMC 450	0,25 mm

TABLE 12

Electric motor, 4-pole, 1500 rpm - B3/B5				Dimensions of LMC monobloc bell-housing												
Frame size	kW	Hp	Shaft	Bell-housing code	Foot bracket code	Damping ring code	D1	D2	D3	D4	H1	H2	F	P	Weight (kg)	
63	0.12-0.18	0.16-0.24	11x23	LMC 140	/	/	95	115	140	100		13	M8	9	0,35	
63	0.12-0.18	0.16-0.24	11x23	LMC 141	/	/	95	115	140	100		13	M8	9	0,35	
71	0.25-0.37	0.34-0.50	14x30	LMC 160	PDM A 160	/	110	130	160	110		15	M8	9	0,44	
71	0.25-0.37	0.34-0.50	14x30	LMC 161	PDM A 160	/	110	130	160	110		15	M8	9	0,44	
80	0.53-0.75	0.75-1	19x40	LMC 200	PDM A 200	ANM A 200	130	165	200	135		18	M10	11	0,68	
90	1.1-1.5	1.5-2	24x50	LMC 201	PDM A 200	ANM A 200	130	165	200	135		18	M10	11	0,80	
100-112	2.2-4	3-5.5	28x60	LMC 250	PDM A 250	ANM A 250	180	215	250	185		19	M12	14	1,16	
132	5.5-7.5	7.5-12.5	38x80	LMC 300	PDM A 300	ANM A 300	230	265	300	235		23	M12	14	2,55	
160	11-15	15-20	42x110	LMC 351	PDM A 350	ANM A 350	250	300	350	255		31	M16	18	4,90	
180	18-22	25-30	48x110	LMC 351	PDM A 350	ANM A 350	250	300	350	255		31	M16	18	4,90	
						For dimension see page 55						For dimension see page 56				
												See Tab. 15-16				

TABLE 13

Electric motor, 4-pole, 1500 rpm - B14				Dimensions of LMC monobloc bell-housing												
Frame size	kW	Hp	Shaft	Bell-housing code	Foot bracket code	Damping ring code	D1	D2	D3	D4	H1	H2	F	P	Weight (kg)	
63	0.12-0.18	0.16-0.24	11x23	LMC 090	/	/	60	75	90	63		7	7	7	0,30	
71	0.25-0.37	0.34-0.50	14x30	LMC 105	/	/	70	85	105	74		8	6	6	0,35	
80	0.53-0.75	0.75-1	19x40	LMC 120	/	/	80	100	120	84		9	7	7	0,35	
90	1.1-1.5	1.5-2	24x50	LMC 141	/	/	95	115	140	100		13	M8	9	0,51	
100-112	2.2-4	3-5.5	28x60	LMC 161	PDM A 160	/	110	130	160	110		15	M8	9	0,60	
						For dimension see page 55						For dimension see page 56				
												See Tab. 17				

To determine dimension H1 of the bell-housing see pages 22 - 23 - 24

Note: For larger dimensions, contact the MP Filtri Technical and Sales Department.

Versions

In order to ensure greater adaptability across a wide range of applications, **LMC** monobloc bell-housings for gear pumps can be supplied in 4 different versions:

LMC *** 4S

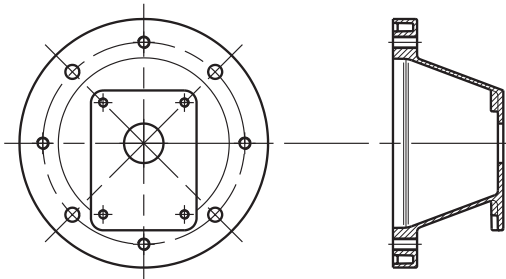

Without centre ring allowing removal of half-coupling (which as a rule is keyed permanently to the pump shaft); motor mounting flange drilled with 4 clearance holes + 4 threaded holes. Used normally for vertically mounted motor and pump units with pump submerged in the oil tank.

LMC *** 8S

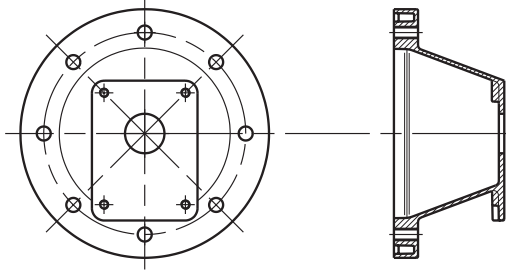

Without centre ring allowing removal of half-coupling (which as a rule is keyed permanently to the pump shaft); motor mounting flange drilled with 8 clearance holes. Used normally for vertically mounted motor and pump units with pump submerged in the oil tank; allows greater flexibility for directional positioning of the hydraulic pump inside the tank, according to constructional requirements.

LMC *** 4E

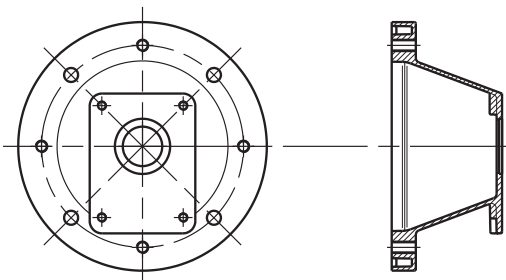

With centre ring allowing removal of half-coupling (which as a rule is keyed permanently to the pump shaft); motor mounting flange drilled with 4 clearance holes + 4 threaded holes. Normally used for motor and pump units mounted horizontally on the tank lid or on the machine, for maximum ease of maintenance. With this type of mounting, in effect, the hydraulic pump can be removed without removing the motor. The half-coupling mounted to the shaft passes through the spigot hole.

LMC *** 8E

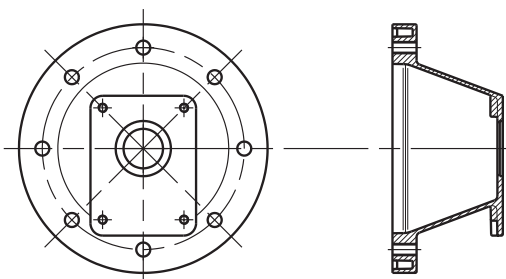

With centre ring allowing removal of half-coupling (which as a rule is keyed permanently to the pump shaft); motor mounting flange drilled with 8 clearance holes. Normally used for motor and pump units mounted horizontally on the tank lid or on the machine; offers maximum ease of maintenance, and enables directional positioning of the pump. With this type of mounting, in effect, the hydraulic pump can be removed without removing the motor. The half-coupling mounted to the shaft passes through the spigot hole.

Designation of pump flange and shaft

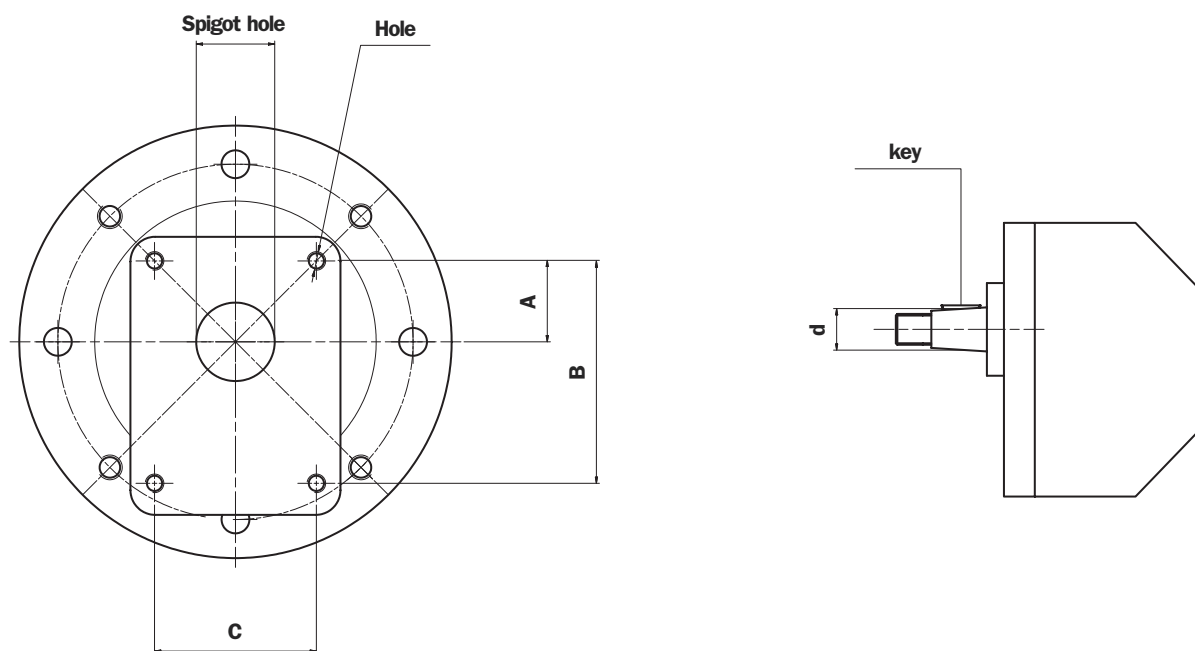

The auxiliary flange, if specified, is supplied already fitted to the bell-housing (MODUL-2).

• For technical information see “DRIVE COUPLINGS”.

TABLE 14

Pump group	Spigot hole	A	B	C	Hole	Pump flange code	Shaft type	d	key	Pump half-coupling code
05	22	25.5	66	/	M6	FS05M	cilindrico	6	2	FS05M
	22	25.5	66	/	M6	FS05C	cilindrico	7	2	FS05C
1	25.4	26.2	72	52	M6	FS100	con. 1:8	9.7	2.4	FS100
	30	24.5	73	56	M6	FS1M0	cilindrico	12	3	FS1C0
	30	24.5	73	56	M6	FS1M0	con. 1:8	13.9	3	FS1M0
2	36.5	32.5	96	71.5	M8	FS200	con. 1:8	17.2	3.2/4	FS200
3	50.8	43	128	98.5	M8	FS25T	con. 1:8	22.2	4	FS300
	50.8	42	128	98.5	M10	FS300	con. 1:8	22.2	4	FS300
	50.8	43	128	98.5	M10	FS3M0	con. 1:8	22.2	4	FS300
	50.8	45	137	98.5	M10	FS3T0	con. 1:8	22.2	4	FS300
3.5	60	48.5	148	127	M12	FS35M	con. 1:8	25.6	4.76/5	FS350
	60.3	49.5	149.5	114.3	M10	FS350	con. 1:8	25.6	4.76/5	FS350
4	63.5	65	196	142.8	M12	FS4M0	con. 1:8	33.3	6.35/7	FS400
	63.5	64.3	188	143	M12	FS400	con. 1:8	33.3	6.35/7	FS400
Bosch	32	10.3	40	40	M8	FSZBR	con. 1:5	9.8	2	FSZBR
	80	34.5	100	72	M8	FSZFR	con. 1:5	16.9	3	FSZFR
	105	48	145	102	M10	FSZGR	con. 1:5	25.2	5	FSZGR

Note: For any dimensions not indicated in Table 14, see tables 15 - 16 - 17 showing motor-pump combinations.

Table of combinations

Electric motors with B3 - B5 flange gear pumps

TABLE 15

Electric motor, 4-pole, 1500 rpm				Components of combination						
Motor size	kW	Hp	Motor shaft	Pump code	Bell-housing code	H1	Motor half-coupling code	Spider code	Pump half-coupling code	Centre ring code
63	0.12 0.18	0.16 0.24	11x23	FS05M	LMC140MFS05M4S	60	SGEA01M01021	EGE 0	SGEA01FS05M	/
				FS05C	LMC140MFS05M4S				SGEA01FS05C	/
				FS100	LMC140MFS100**				SGEA01FS100	ANC01FS100
				FS1C0	LMC140MFS1M0**				SGEA01FS1C0	ANC01FS1M0
				FS1M0	LMC140MFS1M0**				SGEA01FS1M0	ANC01FS1M0
				FSZBR	LMC140MFSZBR4S				SGEA01FSZBR	/
71	0.25 0.37	0.34 0.50	14x30	FS05M	LMC160MFS05M4S	70	SGEA01M02028	EGE 0	SGEA01FS05M	/
				FS05C	LMC160MFS05M4S				SGEA01FS05C	/
				FS100	LMC160MFS100**				SGEA01FS100	ANC01FS100
				FS1C0	LMC160MFS1M0**				SGEA01FS1C0	ANC01FS1M0
				FS1M0	LMC160MFS1M0**				SGEA01FS1M0	ANC01FS1M0
				FSZBR	LMC160MFSZBR4S				SGEA01FSZBR	/
80	0.53 0.75	0.75 1	19x40	FS05M	LMC200MFS05M4S	87	SGEA01M03048	EGE 0	SGEA01FS05M	/
				FS05C	LMC200MFS05M4S				SGEA01FS05C	/
				FS100	LMC200MFS100**				SGEA01FS100	ANC01FS100
				FS1C0	LMC200MFS1M0**				SGEA01FS1C0	ANC01FS1M0
				FS1M0	LMC200MFS1M0**				SGEA01FS1M0	ANC01FS1M0
				FSZBR	LMC200MFSZBR4S				SGEA01FSZBR	/
				FS200	LMC201MFS200**	95	SGEA21M03048	EGE 2	SGEA21FS200	ANC02FS200
				FSZFR	LMC201MFSZFR4S	SGEA21FSZFR	/			
90	1.1 1.5	1.5 2	24x50	FS05M	LMC200MFS05M4S	87	SGEA01M04048	EGE 0	SGEA01FS05M	/
				FS05C	LMC200MFS05M4S				SGEA01FS05C	/
				FS100	LMC200MFS100**				SGEA01FS100	ANC01FS100
				FS1C0	LMC200MFS1M0**				SGEA01FS1C0	ANC01FS1M0
				FS1M0	LMC200MFS1M0**				SGEA01FS1M0	ANC01FS1M0
				FSZBR	LMC200MFSZBR4S				SGEA01FSZBR	/
				FS200	LMC201MFS200**	95	SGEA21M04048	EGE 2	SGEA21FS200	ANC02FS200
				FSZFR	LMC201MFSZFR4S	SGEA21FSZFR	/			
100 112	2.2 4	3 5.5	28x60	FS100	LMC250MFS1004S	105	SGEA21M05055	EGE 2	SGEA21FS100	/
				FS1C0	LMC250MFS1M04S				SGEA21FS1C0	/
				FS1M0	LMC250MFS1M04S				SGEA21FS1M0	/
				FSZBR	LMC250MFSZBR4S				SGEA21FSZBR	/
				FS200	LMC250MFS200**				SGEA21FS200	ANC02FS200
				FSZFR	LMC250MFSZFR4S				SGEA21FSZFR	/
				● FS25T	LMC250MFS25T4E	126	SGEA21FS300	ANC0005		
				● FS300	LMC250MFS3004E		SGEA21FS300	ANC0005		
				● FS3M0	LMC250MFS3M04E		SGEA21FS300	ANC0005		
				● FS3T0	LMC250MFS3T04E		SGEA21FS300	ANC0005		

● Bell-housing with auxiliary flange + centre ring

Note: The two final asterisks in the bell-housing code indicate the version.
See "Ordering information" pages 28 - 29.

Table of combinations

Electric motors with B3 - B5 flange gear pumps

TABLE 16

Electric motor, 4-pole, 1500 rpm				Components of combination						
Motor size	kW	Hp	Motor shaft	Pump code	Bell-housing code	H1	Motor half-coupling code	Spider code	Pump half-coupling code	Centre ring code
132	5.5	7.5	38x80	FS100	LMC300MFS1004S	145	SGEA31M06077	EGE 3	SGEA31FS100	/
				FS1C0	LMC300MFS1M04S				SGEA31FS1C0	/
	FS1M0	LMC300MFS1M04S		SGEA31FS1M0	/					
	FSZGR	LMC300MFSZGR4S		SGEA31FSZGR	/					
	FS200	LMC300MFS200**		SGEA31FS200	ANC03FS200					
	FSZFR	LMC300MFSZFR4S		SGEA31FSZFR	/					
	FS25T	LMC300MFS25T**		SGEA31FS300	ANC03FS300					
	FS300	LMC300MFS300**		SGEA31FS300	ANC03FS300					
	FS3M0	LMC300MFS3M0**		SGEA31FS300	ANC03FS300					
	FS3T0	LMC300MFS3T0**		SGEA31FS300	ANC03FS300					
	FS35M	LMC300MFS35M**		SGEA31FS350	ANC03FS350					
	FS350	LMC300MFS350**		SGEA31FS350	ANC03FS300					
160	11	15	42x110	FSZGR	LMC351MFSZGR4S	179	SGEA51M07109	EGE 5	SGEA51FSZGR	/
				FS200	LMC351MFS2004S				SGEA51FS200	/
	FSZFR	LMC351MFSZFR4S		SGEA51FSZFR	/					
	FS25T	LMC351MFS25T**		SGEA51FS300	ANC04FS300					
	FS300	LMC351MFS300**		SGEA51FS300	ANC04FS300					
	FS3M0	LMC351MFS3M0**		SGEA51FS300	ANC04FS300					
	FS3T0	LMC351MFS3T0**		SGEA51FS300	ANC04FS300					
	FS35M	LMC351MFS35M**		SGEA51FS350	ANC04FS350					
	FS350	LMC351MFS350**		SGEA51FS350	ANC04FS350					
	180	18.5		25	48x110				FSZGR	LMC351MFSZGR4S
FS200			LMC351MFS2004S			SGEA51FS200	/			
FSZFR		LMC351MFSZFR4S	SGEA51FSZFR	/						
FS25T		LMC351MFS25T**	SGEA51FS300	ANC04FS300						
FS300		LMC351MFS300**	SGEA51FS300	ANC04FS300						
FS3M0		LMC351MFS3M0**	SGEA51FS300	ANC04FS300						
FS3T0		LMC351MFS3T0**	SGEA51FS300	ANC04FS300						
FS35M		LMC351MFS35M**	SGEA51FS350	ANC04FS350						
FS350		LMC351MFS350**	SGEA51FS350	ANC04FS350						

For dimensions of motor half-coupling see page 25

For dimensions of spiders see page 49

For dimensions of pump half-coupling see page 25

Note: The two final asterisks in the bell-housing code indicate the version.

See "Ordering information" pages 28 - 29.

Table of combinations

Electric motors with B14 flange gear pumps

TABELLA 17

Electric motor, 4-pole, 1500 rpm				Components of combination							
Motor size	kW	Hp	Motor shaft	Pump code	Bell-housing code	H1	Motor half-coupling code	Spider code	Pump half-coupling code	Centre ring code	
63	0.12 0.18	0.16 0.25	11x23	FS05M	LMC090MFS05M4E	60	SGEA01M01021	EGE 0	SGEA00FS05M	ANCA001	
				FS05C	LMC090MFS05M4E				SGEA01FS05C	ANCA001	
				FS100	LMC090MFS1004E				SGEA01FS100	ANCO1FS100	
				FS1C0	LMC090MFS1M04E				SGEA01FS1C0	ANCO1FS1M0	
				FS1M0	LMC090MFS1M04E				SGEA01FS1M0	ANCO1FS1M0	
				FSZBR	LMC090MFSZBR4E				SGEA01FSZBR	/	
71	0.25 0.37	0.35 0.55	14x30	FS05M	LMC105MFS05M4E	67	SGEA01M02028	EGE 0	SGEA01FS05M	ANCA001	
				FS05C	LMC105MFS05M4E				SGEA01FS05C	ANCA001	
				FS100	LMC105MFS1004E				SGEA01FS100	ANCO1FS100	
				FS1C0	LMA105MFS1C04E				SGEA01FS1C0	ANCO1FS1M0	
				FS1M0	LMC105MFS1M04E				SGEA01FS1M0	ANCO1FS1M0	
				FSZBR	LMC105MFSZBR4E				SGEA01FSZBR	/	
80	0.55 0.75	0.75 1	19x40	FS05M	LMC120MFS05M4E	87	SGEA01M03048	EGE 0	SGEA01FS05M	ANCA001	
				FS05C	LMC120MFS05M4E				SGEA01FS05C	ANCA001	
				FS100	LMC120MFS1004E				SGEA01FS100	ANCO1FS100	
				FS1C0	LMC120MFS1M04E				SGEA01FS1C0	ANCO1FS1M0	
				FS1M0	LMC120MFS1M04E				SGEA01FS1M0	ANCO1FS1M0	
				FSZBR	LMC120MFSZFR4S				SGEA01FSZBR	/	
				FS200	LMC121MFS2004E	95	SGEA21M03048	EGE 2	SGEA21FS200	ANC02FS200	
				FSZFR	LMC121MFSZFR4S	SGEA21FSZFR	/				
90	1.1 1.5	1.5 2	24x50	FS05M	LMC141MFS05M4S	95	SGEA01M04048	EGE 0	SGEA01FS05M	ANCA001	
				FS05C	LMC141MFS05M4S				SGEA01FS05C	ANCA001	
				FS100	LMC141MFS100**				SGEA01FS100	ANCO1FS100	
				FS1C0	LMA141MFS1M0**				SGEA01FS1C0	ANCO1FS1M0	
				FS1M0	LMC141MFS1M0**				SGEA01FS1M0	ANCO1FS1M0	
				FSZBR	LMC141MFSZBR4S				SGEA01FSZBR	/	
				FS200	LMC141MFS200**	95	SGEA21M04048	EGE 2	SGEA21FS200	ANC02FS200	
				FSZFR	LMC141MFSZFR4S	SGEA21FSZFR	/				
100 112	2.2 4	3 5.5	28x60	FS05M	LMC161MFS05M4S	105	SGEA21M05055	EGE 2	SGEA21FS05M	/	
				FS05C	LMC161MFS05M4S				SGEA21FS05C	/	
				FS100	LMC161MFS1004S				SGEA21FS100	/	
				FS1C0	LMC161MFS1M04S				SGEA21FS1C0	/	
				FS1M0	LMC161MFS1M04S				SGEA21FS1M0	/	
				FSZBR	LMC161MFSZBR4S				SGEA21FSZBR	/	
				FS200	LMC161MFS200**				SGEA21FS200	ANC02FS200	
				FSZFR	LMC161MFSZFR4S				SGEA21FSZFR	/	

For dimensions of motor half-coupling see page 25

For dimensions of spiders see page 49

For dimensions of pump half-coupling see page 25

Note: The two final asterisks in the bell-housing code indicate the version.

See "Ordering information" pages 28 - 29.

Dimensions of SGEA series motor half-coupling aluminium

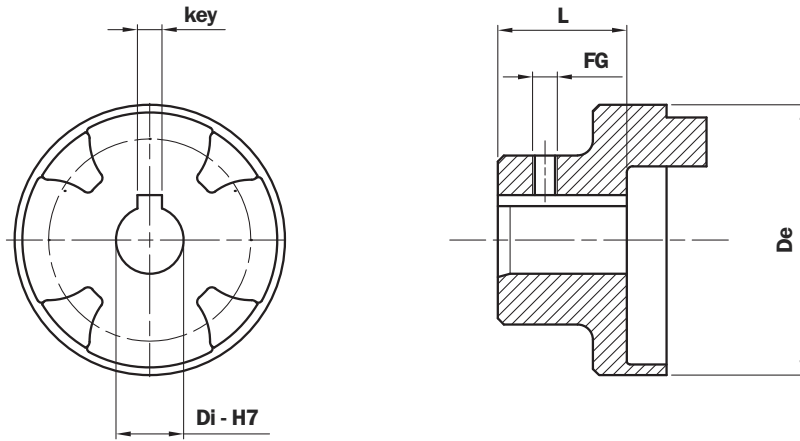

TABLE 18

Half-coupling code	De	L	Di	key	FG
SGEA01M01021	44	21	11	4	M5
SGEA01M02028	44	28	14	5	M5
SGEA01M03048	44	48	19	6	M5
SGEA01M04048	44	48	24	8	M5

Half-coupling code	De	L	Di	key	FG
SGEA21M05055	65	55	28	8	M6
SGEA31M06077	85	77	32	10	M8
SGEA51M07109	105	109	42	12	M8
SGEA51M08109	105	109	48	14	M8

Note: Screw not included

Dimensions of SGEA series pump half-coupling aluminium

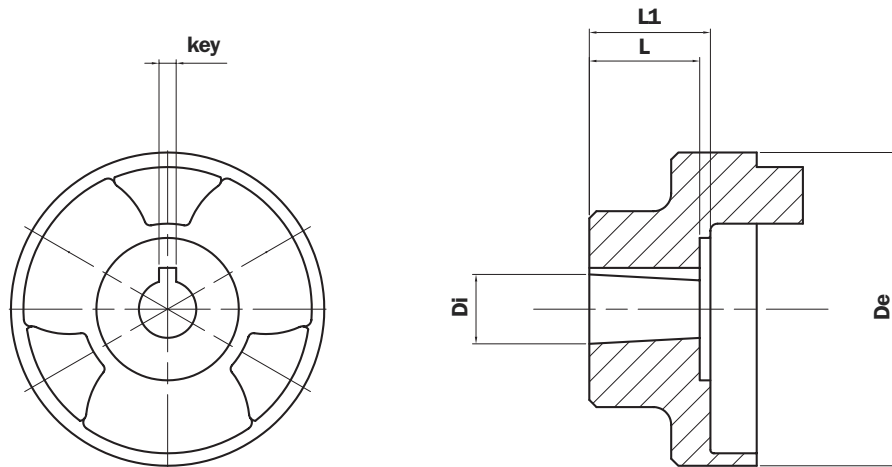

TABLE 19

Half-coupling code	De	L	L1	Di	key
SGEA01FS05M	44	10	16	06	2
SGEA01FS05C	44	10	16	07	2
SGEA01FS100	44	14,5	16	9,7	2,4
SGEA01FS1M0	44	16	16	13,9	3
SGEA01FS1C0	44	16	16	12	3
SGEA01FSZBR	44	16	16	9,8	2
SGEA21FS100	65	14,5	21,5	9,7	2,4
SGEA21FS1C0	65	16	21,5	12	3
SGEA21FS1M0	65	16	21,5	13,9	3
SGEA21FS200	65	21,5	21,5	17,2	3,2-4
SGEA21FSZFR	65	20	21,5	16,9	3
SGEA21FS300	65	27	41	21,6	4

Half-coupling code	De	L	L1	Di	key
SGEA31FS100	85	14,5	37	9,7	2
SGEA31FS1C0	85	16	37	12	2
SGEA31FS1M0	85	16	37	13,9	2,4
SGEA31FS200	85	23	37	17,2	3,2-4
SGEA31FS300	85	27	37	21,6	4
SGEA31FS350	85	35	37	25,6	4,76-5
SGEA31FSZFR	85	20	37	16,9	3
SGEA31FSZGR	85	27	34	25,2	5
SGEA51FS200	105	21,5	32	17,2	3,2-4
SGEA51FS300	105	27	32	21,6	4
SGEA51FS350	105	35	32	25,6	5
SGEA51FSZFR	105	20	32	16,9	3
SGEA51FSZGR	105	27	32	25,2	5

Comparative table - Bell-housing

MP Filtri		OMT	Hydrapp	Raja	KTR
New code	Old code	Code	Code	Code	Code
LMC140MFS05M**	LMB140A060A001	LS140	/	/	/
LMC140MFS05C**	LMB140A060A001	LS140	/	/	/
LMC140MFS100**	LMB140A060A002	LS141	/	L45	/
LMC140MFS1C0**	LMB140A060A003	LS142	/	/	/
LMC140MFS1M0**	LMB140A060A003	LS142	/	B45	/
LMC140MFSZBR**	LMB140A060S013	LBS18	/	Bo45	/
LMC160MFS05M**	LMB160A067A001	LS160	HL1	H9	PL160/1/...
LMC160MFS05C**	LMB160A067A001	LS160	HL2	H9	PL160/1/...
LMC160MFS100**	LMB160A067A002	LS161	HL2	L9	PL160/1/...
LMC160MFS1C0**	LMB160A067A003*	LS162	HL3	L9	PL160/1/...
LMC160MFS1M0**	LMB160A067A003	LS162	HL4	B9	PL160/1/...
LMC160MFSZBR**	LMB160A067S013	LBS19	HLB1	Bo9	PL160/1/...
LMC200MFS05M**	LMB200A087A001	LS210	HL4L	H2	PL200/1/...
LMC200MFS05C**	LMB200A087A001*	LS210	HL4L	H2	PL200/1/...
LMC200MFS100**	LMB200A087A002	LS211	HL5L	L2	PL200/1/...
LMC200MFS1C0**	LMB200A087A003	LS212	HL6L	B2	PL200/1/...
LMC200MFS1M0**	LMB200A087A003	LS212	HL6L	B2	PL200/1/...
LMC200MFSZBR**	LMB200A087S013	LBS28	HLB3L	Bo2	PL200/1/...
LMC201MFS200**	LMB200A095C004	LS203	HL7SL	L7/4	PL200/2/...
LMC201MFSZBR**	LMB200A098S014	LS203	HLB12SL	Bo7	PL200/2/...
LMC250MFS100**	LMB250A109C002	LS250	HL8/1L	L6/3	PL250/1/...
LMC250MFS1C0**	LMB250A109C003	LS251	HL8L	B5	PL250/1/...
LMC250MFS1M0**	LMB250A109C003	LS251	HL8L	B5	PL250/1/...
LMC250MFSZBR**	LMB250A109S013	LBS22	HLB13L	Bo5	PL250/1/...
LMC250MFS200**	LMB250A109C004	LS252	HL9L	L6/3	PL250/1/...
LMC250MFSZFR**	LMB250A109S014	LBS23	HLB17L	Bo6	PL250/1/...
LMC250MFS25T**	LMB250A126D005	LS254	HL11	L4/3	PL250/7/...
LMC250MFS300**	LMB250A126D006	LBS25	HL11	L4/3	PL250/7/...
LMC250MFS3M0**	LMB250A126D007	LS256	HL11	L4/3	PL250/7/...
LMC250MFS3T0**	LMB250A126D006	LS257	HL11T	L34	PL250/7/...
LMC300MFS100**	/	LS210	/	/	PL300/2/...
LMC300MFS1C0**	/	LS211	/	/	PL300/2/...
LMC300MFS1M0**	/	LS311	/	/	PL300/2/...
LMC300MFSZBR**	/	/	/	/	PL300/2/...
LMC300MFS200**	LMB300A130D004	LS300	HL12	L13	PL300/2/...
LMC300MFSZR**	LMB300A130S014	LBS26	HLB22	Bo13	PL300/2/...
LMC300MFS25T**	LMB300A147D005	LS301	HL13	L12	PL300/2/...
LMC300MFS300**	LMB300A147D005	LS302	HL13	L12	PL300/2/...
LMC300MFS3M0**	LMB300A147D005	LS303	HL13	L12	PL300/2/...
LMC300MFS3T0**	LMB300A147D006	LS304	HL13T	L14	PL300/2/...
LMC300MFS35M**	/	LS305	/	L16	PL300/2/...
LMC300MFS350**	/	LS306	HLB28	L15	PL300/2/...
LMC351MFSZGR**	/	LBS27	HL15	Bo14	PL350/2/...
LMC351MFS200**	LMB350A160D004	LS350	HLB27	L17	PL350/2/...
LMC351MFSZR**	LMB350A160S014	LBS31	/	Bo18	PL350/2/...
LMC351MFS25T**	LMB350A179F005	LS351	/	L18	PL350/2/...
LMC351MFS300**	LMB350A179F005	LS352	/	L18	PL350/2/...
LMC351MFS3M0**	LMB350A179F005	LS353	/	L18	PL350/2/...
LMC351MFS3T0**	LMB350A179F006	LS354	/	L19	PL350/2/...
LMC351MFS35M**	/	LSE355	/	L21	PL350/2/...
LMC351MFS350**	/	LSE356	/	L20	PL350/2/...
LMC351MFSZGR**	/	LBS32	/	Bo19	PL350/2/...
LMC351MFS200**	LMB350A160D004	LS350	HL15	L17	PL350/2/...
LMC351MFSZR**	LMB350A160S014	LBS31	HLB27	Bo18	PL350/2/...
LMC351MFS25T**	LMB350A179F005	LS351	/	L18	PL350/2/...
LMC351MFS300**	LMB350A179F005	LS352	/	L18	PL350/2/...
LMC351MFS3M0**	LMB350A179F005	LS353	/	L18	PL350/2/...
LMC351MFS3T0**	LMB350A179F006	LS354	/	L19	PL350/2/...
LMC351MFS35M**	/	LSE355	/	L21	PL350/2/...

Note: The above table is guideline only.

All bell-housings of the MP Filtri range can be considered equivalent to the counterpart brands listed.

For further information, contact the MP Filtri Technical and Sales Department.

Comparative table - Half-coupling

MP Filtri		OMT
New code	Old code	Code
SGEA01FS05M	SGEA00B01018	ND48P05M
SGEA01FS05C	SGEA00B02018	ND48P05GT
SGEA01FS100	SGEA00B07018	ND48PU1P
SGEA01FS1C0	SGEA00B03014	ND48P1C
SGEA01FS1M0	SGEA00B06016	ND48PIM
SGEA01FSZBR	SGEA00B08014	ND48PZB
SGEA21FS100	SGEA20B07018	ND65PU1P
SGEA21FS1C0	SGEA20B03024	ND65P1C
SGEA21FS1M0	SGEA20B06024	ND65P1M
SGEA21FSZBR	SGEA20B08024	ND65PZB
SGEA21FS200	SGEA20B100242A	ND65P2
SGEA21FSZFR	SGEA20B13024	ND65PZF
SGEA21FS25T	SGEA20B16041	ND65Q3U
SGEA31FS100	SGEA30B07022	ND86PU1P
SGEA31FS1C0	/	ND86P1C
SGEA31FS1M0	SGEA30B06021	ND86P1M
SGEA31FSZBR	/	/
SGEA31FS200	SGEA30B100222A	ND86P2
SGEA31FSZFR	SGEA30B13020	ND86PZF
SGEA31FS300	SGEA30B16038	ND86P3U
SGEA31FS350	SGEA30B180382B	/
SGEA51FSZGR	SGEA50B17034	/
SGEA51FS200	/	/
SGEA51FSZFR	SGEA50B13032	ND108PZF
SGEA51FS300	SGEA50B16032	ND108P3U
SGEA51FS350	SGEA50B180342B	ND108Q35
SGEA51FS400	SGEA50B210462C	/

Note: The above table is guideline only.

Not all half-couplings are fully interchangeable.

For further information, contact the MP Filtri Technical and Sales Department.

Ordering information AKA

Complete coupling kit AKA

Example: AKA

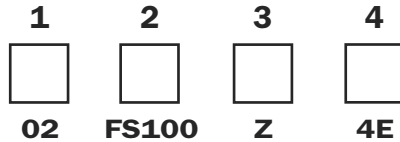

1 - Sizes

02	Size 63 B3-B5
03	Size 71 B3-B5
04	Size 80 B3-B5
05	Size 90 B3-B5
07	Size 100/112 B3-B5
11	Size 132 B3-B5
12	Size 160 B3-B5
13	Size 180 B3-B5
43	Size 63 B14
44	Size 71 B14
45	Size 80 B14
46	Size 90 B14
48	Size 100/112 B14

2 - Pump identification code

See table 14 page 21

3 - Product revision code

4 - Versions

4S] See page 20
4E	
8S	
8E	

Ordering information AKG

Coupling kit AKG

Example: AKG

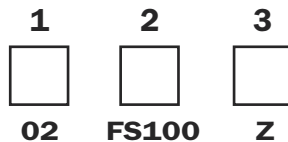

1 - Sizes

02	Size 63 B3-B5
03	Size 71 B3-B5
04	Size 80 B3-B5
05	Size 90 B3-B5
07	Size 100/112 B3-B5
11	Size 132 B3-B5
12	Size 160 B3-B5
13	Size 180 B3-B5
43	Size 63 B14
44	Size 71 B14
45	Size 80 B14
46	Size 90 B14
48	Size 100/112 B14

2 - Pump identification code

See table 14 page 21

3 - Product revision code

Note: For customization features other than those indicated on this page, contact the Technical and Sales Department

A guide to select the correct bell-housing and drive coupling components

DATA REQUIRED

Electric motor power/motor size
 Manufacturer and pump type

TO VERIFY:

- 1 - Pump and motor shaft dimensions (see page 69)
- 2 - Shaft and flange pump (see pump data sheet)

Example:

- Electric motor 2 kW - 4 poles - Motor size 110/112
- Atos pump code PFE31 - Shaft 1

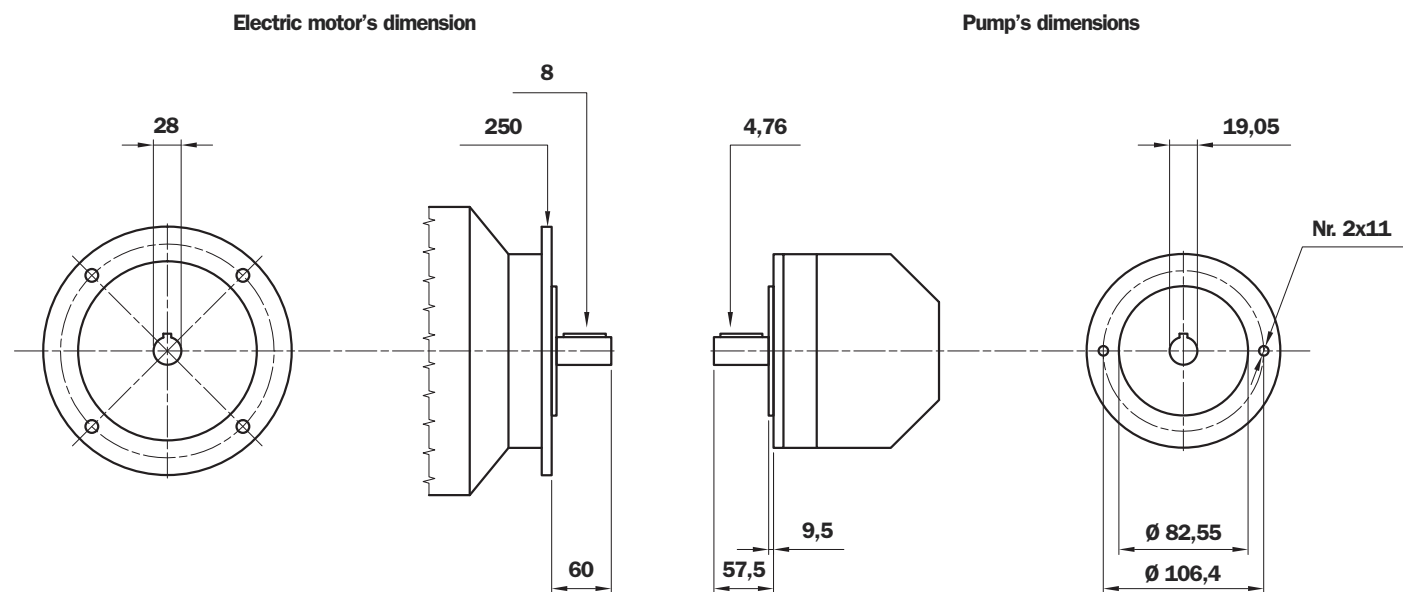

Bell-Housing's length calculation

- $H = 60 + 18 + 57,5 = 135,5$ mm (18= Sp spider - see page 49)
- Choose type of bell-housing (LMC - LMS)
 - For LMC see tab. 3 at page 11
 - For LMS see tab. 21 at page 32
 - For MODUL 2/3 see at page 36

Note: The length of bell-housing must be \geq than the length calculated (135,5 mm)

Case A - solution with LMC bell-housing

Tab. 3 at page 11 - for electric motor 2kW LMC 250
 LMC 250 bell-housing with height $\geq 135,5$ - LMC250AFSQ

- The bell-housing code must be completed with drilling pump code (see tab. 34 at page 47)
 For the specific case C= 101,6 - Nr. 2 holes M10: Code drilling 070
- Definitive bell-housing code **LMC250AFSQ070**

Case B - solution with LMS bell-housing

Tab. 21 at page 32 - for electric motor 2kW LMS 250
 LMS 250 bell-housing with height $\geq 135,5$ - LMS250AFSQ

- The bell-housing code must be completed with drilling pump code (see tab. 34 at page 47)
 For the specific case C= 101,6 - Nr. 2 holes M10: Code for. 070
- Definitive bell-housing code **LMS250AFSQ070**

Choose coupling

- **Motor half-coupling** (see tab. 37 at page 50)
 - For electric motor GR 100/112, the half-coupling is **SGEA21M05060**
- **Spider** (see tab. 35 - 36 at page 49)
 - For SGEA21, EGE2 - EGE2RR
(choose spider material on the base of the application, oil, temperature and cycle machine, etc.)
- **Pump half-coupling**
 - Choose the drilling code tab. 43 - 44 at page 53 for shaft 19,05 - Ch. 4,76 - code: **G01**
 - Half-coupling length = L BH length - THK Spider - THK Spigot
 $138 \text{ mm} - 60 - 18 - 9,5 = 50,5 \text{ mm}$
 - Choose the half-coupling's length on tab. 38 at page 50 $\leq 50,5 \text{ mm}$.
 - Availabe length for SGEA21= 50 mm
 - Code half-coupling code: **SGEA21G01050**

**Software for automatic calculation available on the web site
www.mpfiltri.com - tools - software**

The screenshot shows a software interface for calculating pump and motor coupling. It includes sections for AKA, Pump, Electric Motor, HYDRAULIC PUMP - Technical Data, and ELECTRIC MOTOR - Technical Data. The interface also features a 'Coupling material' section with radio buttons for Aluminum, Cast iron, and Alternative material. The 'Result' section displays the selected coupling (M01 - 21066), drilling pump (5000), pump shaft (G01), and motor shaft (M01). A 'CLICK HERE TO PROCEED' button is visible at the bottom left. On the right, there are status indicators for different bearing types and a text box with instructions.

Note: For multi pumps we recommend to use a specific support on the base of the pump's dimensions and weight.

Half-coupling SGE*** series

The half-couplings series SGE*** allow secure transmission between the electric motor and the driven side; they are able to absorb shocks and vibration, in addition to compensating radial misalignment, angular and axial.

The assembly of the couplings can be horizontal/vertical, withstanding vibration and load reversals.

The complete range of couplings are extrapolated from the on-line software, with a length equal than the shaft on which must be mounted and they are completed with grub screw for fixing located on the key.

Available for cylindrical shaft with metric and imperial dimensions as well for splined shafts as per specification DIN, ISO and SAE.

Admissible misalignment radial, angular and axial

Max admissible radial misalignment

Half coupling	R (mm)
SGE * 01	0,5
SGE * 21	1,0
SGE * 31	1,0
SGE * 40	1,0
SGE * 51	1,5
SGE * 60	1,5
SGE * 80	2,0
SGE * 90	2,0

Max admissible angular misalignment

Half coupling	β (°)
SGE * 01	
SGE * 21	
SGE * 31	
SGE * 40	1,5°
SGE * 51	
SGE * 60	
SGE * 80	
SGE * 90	

Max admissible angular misalignment

Half coupling	A (mm)
SGE * 01	2,0
SGE * 21	2,5
SGE * 31	3,0
SGE * 40	3,5
SGE * 51	3,5
SGE * 60	3,5
SGE * 80	4,0
SGE * 90	5,0

Normative ATEX 94/9/CE

Half-couplings SGE*** series are available to use in hazardous area.

The couplings are certified according to ATEX 94/9/CE (ATEX 95).

Category certified 2G - area 1 and 2.

Other information available on our web site "www.mpfiltri.com".

MP Filtri couplings are developed with:

CAD 3D



FEM (calculation)



Drawings 3D available on website www.mpfiltri.com at section TOOLS/2D-3D COMPONENTS

The half-couplings SGE*** series are in conformity to normative **DIN 740/2**.
The max torque to transmit is always less than the max torque that the coupling can transmit.

Examples verification of the coupling

Torque transmitted by electric motor:

Mt: $9560 \times \text{kW} / \text{rpm} = \text{Nm}$

Me > $\text{Mt} \times \text{S} = \text{Nm}$

Where:

Mt: Torque transmitted by electric motor

Me: Torque transmitted by coupling (see table 14)

kW: Power of electric motor

Rpm: Revolutions per minute of electric motor

S: Service factor (see table 14)

TABLE 1

Small pumps, uniform load, low operating pressures e.g. rotary action machine tools - 5/8 work cycles per hour	1.3
Small pumps, uniform load, high working pressures e.g. lifting equipment - 120-150 work cycles per hour	1.5
Pumps, non-uniform load e.g. lifting equipment - 280-300 work cycles per hour	1.7

Example

Electric motor, 4 pole - 4 kW

hydraulic pump, uniform load, low operating pressure

Mt: $9560 \times 4 / 1500 = 25.45 \text{ Nm}$

Me > $25.49 \times 1.3 = 33 \text{ Nm}$

Half-coupling SGEA21 meets the above requirement.

Select the half-coupling of the calculated size from the motor half-couplings table.

Note: When selecting the coupling, remember that for pumps with splined shaft, only cast iron couplings of the SGEG series can be used.

Determine the size of the coupling according to the type of installation and application envisaged, on the basis of the following formulas and tables:

TABLE 2

Half-coupling type	External diameter mm	Nominal torque Me - Nm	Maximum transmissible torque Me - Nm	
ALUMINIUM	SGEA01	43	15	20
	SGEA21	68	160	190
	SGEA31	85	340	380
	SGEA51	109,5	550	620
CAST IRON	SGEG01	40	20	30
	SGEG30	80	400	450
	SGEG40	95	550	620
	SGEG60	120	760	850
	SGEG80	160	2200	2500
	SGEG90	200	5500	6100
STEEL	SGES40	95	550	620
	SGES60	120	760	850
	SGES80	160	2200	2500

Nominal and maximum torque values are referred to couplings assembled with standard flexible spiders of the **EGE**** series (see page 49).

Where higher torques are to be transmitted, use flexible spiders of the **EGE**RR** series (see page 49).

Noise

Noise is a particularly pervasive problem so much so that there have been statutory regulations in place now for some years, designed to limit harmful occupational exposure. Many of the machines used in industry today are equipped with oil-hydraulic systems, which happen to be a major source of noise.

1. Theory and definition of noise

From a health and hygiene standpoint, noise can be defined as an unpleasant and undesirable sound, or an unpleasant and annoying or intolerable auditory sensation (noise being any sound phenomena that may be accompanied by sensations of disturbance and pain). By definition, acoustic phenomena are oscillatory in character, propagated in a flexible medium and causing pressure variations at the points, and the areas adjacent to those points, through which they pass.

2. Sound

Technically considered, certain elements must be present simultaneously for acoustic phenomena to occur:

- Sound source
- Transmission medium
- Receiver

Motor and pump unit

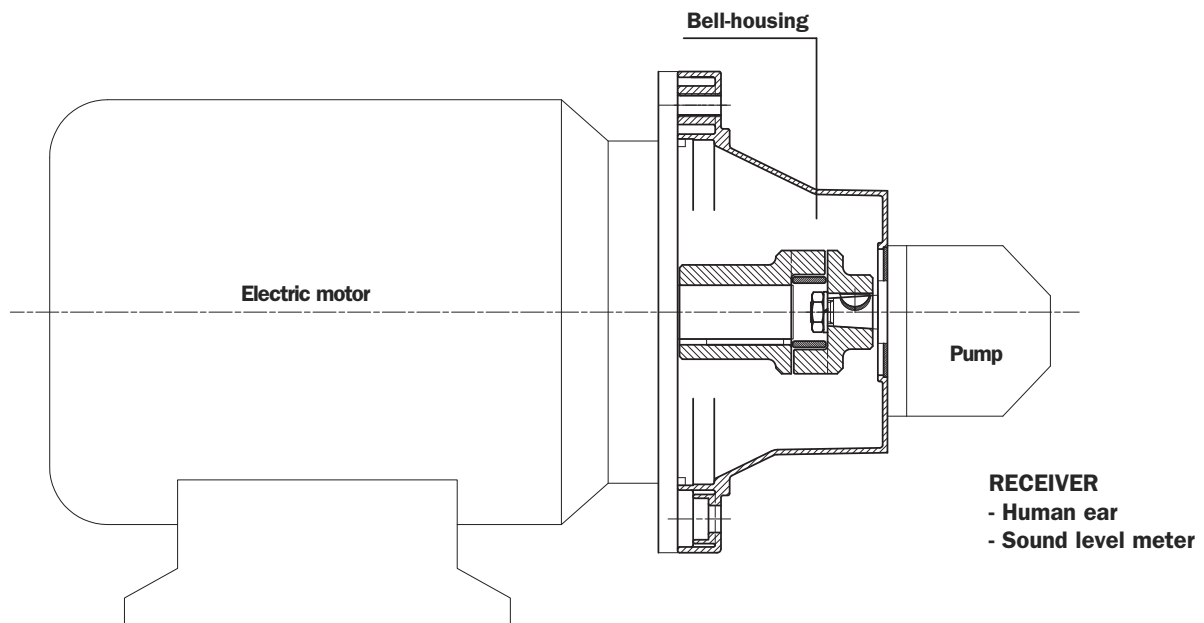

The **electric motor** and the **pump**, together with the drive coupling, are the **SOURCE OF THE NOISE**.

The **Bell-housing** is the noise transmission medium.

Depending on whether the monobloc bell-housing is a rigid or low noise type, there will be variations in the flexible properties of the transmission medium.

The acoustic phenomena are dissimilar in the two cases, given the differences in pressure variation and particle displacement.

Assembly of motor and pump unit

As mentioned in the presentation, low noise bell-housing will help to attenuate the transmission of vibrations and the emission of noise generated by the system.

Self-evidently, however, the mere adoption of a low noise bell-housing will achieve little unless the motor and pump are correctly installed on the machine, or on the tank of the hydraulic power unit.

- Should be followed in order to achieve best possible results and correct installation:

1. Motor and pump unit mounted horizontally on oil tank lid

- The suction pipe attached to the pump must be rigid, and fitted using a resilient bulkhead flange of the FTA series, which helps to cushion the vibrations propagated between the pipe and the tank lid. If pipes need to be bent, the radius of curvature must be at least 3 times the pipe diameter. Do not use elbow fittings, as these will significantly increase pressure losses.
- The pressure pipeline of the pump must be flexible, and long enough to include bends with the minimum radius of curvature recommended by the manufacturer for the specified operating pressure.
- The return pipeline running from the service to the filter must be flexible. Where oil is returned directly to the tank of the hydraulic power unit through a rigid pipe, it is advisable to use a resilient bulkhead flange of the FTR series, which helps to cushion the vibrations propagated between the pipe and the tank lid.
- Anti-vibration devices (resilient mounts or damping rods) must be located under the feet of the electric motor or the PDM foot brackets, depending on the mounting position of the motor.
- The lids of hydraulic oil tanks must be sturdy enough to support the load they carry.

2. Motor and pump unit mounted horizontally on machine

- As a matter of good practice, the oil tank and motor-pump unit should be mounted on a single supporting frame of strength sufficient to support the load.
- If the hydraulic system is fitted with a side-mounted filter, the suction pipeline to the pump must be flexible, and long enough to include bends with the minimum radius of curvature recommended by the manufacturer.
- If the suction filter is not side mounted, the pipeline should be rigid and installed in conjunction with a compensating coupling.
- The pressure pipeline of the pump must be flexible, and long enough to include bends with the minimum radius of curvature recommended by the manufacturer for the specified operating pressure.
- The return pipeline running from the service to the filter must be flexible. Where oil is returned directly to the tank of the hydraulic power unit through a rigid pipe, it is advisable to use a resilient bulkhead flange of the FTR series, which helps to cushion the vibrations propagated between the pipe and the tank lid.
- Anti-vibration devices (resilient mounts or damping rods) must be located under the feet of the electric motor or the PDM foot brackets, depending on the mounting position of the motor.

Note: The above guidelines are indicative only, and subordinate to the solutions adopted ultimately by design engineers.

In conclusion: For best results, in any event, the motor-and-pump unit should be incorporated into the hydraulic system in such a way that no one component is rigidly associated with another, resulting in the propagation of vibration, and consequently noise.

Table of summary MODUL 2/3

	5.5 - 7.5 kW	11 - 22	30	37 - 45	55 - 90	110 - 200	250 - 400
	7.5 - 10.2 Hp	15 - 30 Hp	40.80 Hp	50.32 - 61.2 Hp	75 - 125 Hp	150 - 272 Hp	340 - 544 Hp
	Size 225 - D.450	Size 160/180 D.350	Size 200 - D.350	Size 225 - D.450	Size 250/280 D.550	Size 315 - D.660	Size 355/400 D.800
MODUL 2	<p>AR*</p> <p>BMT300 BMT350</p> <p>FR1*</p> <p>Kit of assembly KVG5 (Q.ty 1) + Kit of assembly KVG1 (Q.ty 1)</p>						
	<p>AD*</p> <p>BMT350 BMT400 BMT450</p> <p>FP5 FP6 FP7</p> <p>Kit of assembly KVG5/7 (Q.ty 2)</p>						
MODUL 3	<p>BMT550 BMT660 BMT800</p> <p>FP6 FP7 (BAD800 ONLY FP7)</p> <p>Kit of assembly KVG6/7 (Q.ty 1)</p>						
	5.5 - 7.5 kW	11 - 22	30	37 - 45	55 - 90	110 - 200	250 - 400
7.5 - 10.2 Hp	15 - 30 Hp	40.80 Hp	50.32 - 61.2 Hp	75 - 125 Hp	150 - 272 Hp	340 - 544 Hp	340 - 544 Hp
Size 225 - D.450	Size 160/180 D.350	Size 200 - D.350	Size 225 - D.450	Size 250/280 D.550	Size 315 - D.660	Size 355/400 D.800	Size 355/400 D.800

Low noise bell-housings

LMS series

Bell-housings of this type, appropriately installed in hydraulic systems, are able to help bring about a significant reduction in the level of noise generated by the system.

This is achieved through the adoption of a damping element located between the base of the bell-housing and the pump mounting flange.

Thanks to their notable versatility and to the broad selection of bases and flanges available, **LMS** low noise bell-housings will cover the majority of applications within a range including electric motors from size 100, rated **2.2 kW**, up to size 280, rated **90 kW**

Technical specifications

LMS

Materials

- **Base module**
Pressure diecast aluminium alloy.
- **Damping ring**
Oil-resistant rubber, Shore A hardness 87.
- **Pump flange**
Pressure diecast aluminium alloy.
- **Foot bracket**
Pressure diecast aluminium alloy.

Temperature

- $-30^{\circ}\text{C} \div +80^{\circ}\text{C}$
For temperatures outside this range, contact the MP Filtri Technical and Sales Department

Compatibility with fluids

- **Base modules compatible for use with:**
 - Mineral oils**
Types HH-HL-HM-HR-HV-HG, to ISO 6743/4 standard
 - Water based emulsions**
Types HFAE - HFAS, to ISO 6743/4 standard
 - Water glycol**
Type HFC, to ISO 6743/4 standard
- Ask for anodized version**

Special Applications

- **Any applications not covered by the normal indications contained in this catalogue must be evaluated and approved by the MP Filtri Technical and Sales Department.**



Technical specifications

Maximum admissible load for LMS low noise bell-housings

TABLE 20

Bell-housing	Max permissible load "F" (N)	Load application distance "S" (mm)
LMS 250	600	200
LMS 300	1000	200
LMS 350	1500	200
LMS 400	2200	200
LMS 450	4000	200
LMS 550	4000	200

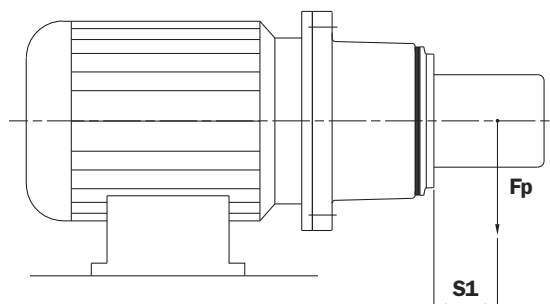

Maximum permissible load values have been calculated assuming the assembly of a pump with its centre of gravity located at a distance **S**= 200 mm from the mounting face.

If the distance "**S**" is greater than this assumed value, then calculate the new permissible load value

"**F1**" using this formula:

$$F_1 = F \times S_1 / S \text{ (N)}$$

Examples

Low noise bell-housing: LMS250
 Fp pump: 600 N
 S1: 220 mm

$$F_1 = 600 \times 220 / 200 = 660 \text{ N} > 600 \text{ N} \text{ (value not acceptable)}$$

Low noise bell-housing: LMS250
 Fp pump: 600 N
 S1: 190 mm

$$F_1 = 600 \times 190 / 200 = 570 \text{ N} < 600 \text{ N} \text{ (value acceptable)}$$

Reduction of noise level

The level of noise emitted by a motor-pump unit depends on several factors, namely:

- Type of pump
- Nature of application
- Operating pressure
- Fittings used for connections
- Type of assembly

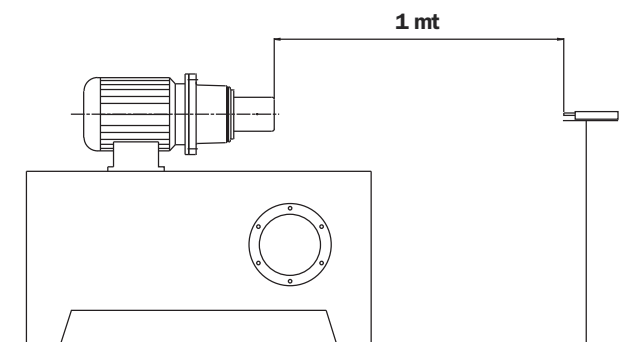

All tests were conducted in an anechoic-chamber, using certified sound level meters.

All LMS series bell-housings were tested adopting the arrangement illustrated above, comparing the noise level with that emitted by conventional monobloc bell-housings of the same size, under the same pressure and flow rate conditions.

- **The results of the tests show that with LMS series low noise bell-housings, the noise level of the motor-pump unit is reduced by 5 Db (A).**

Low noise bell-housing

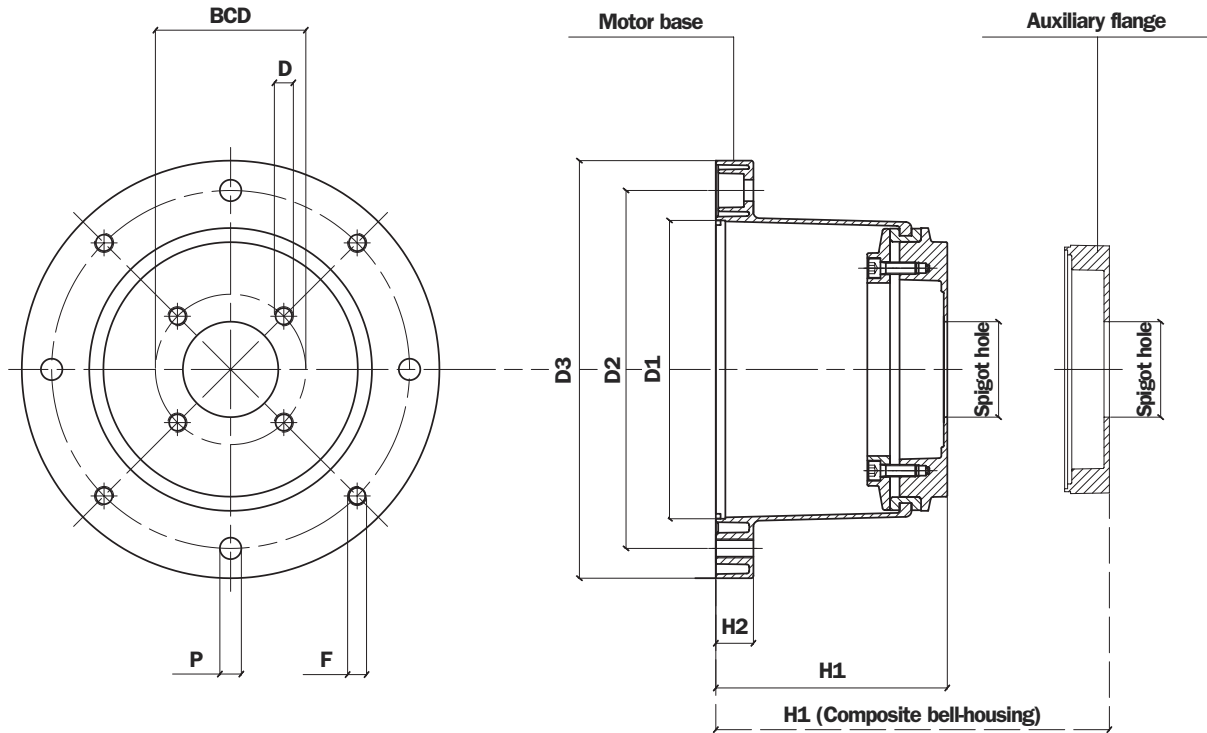

- The auxiliary flange, if specified, is supplied already fitted to the bell-housing.

Note: In order to ensure coaxial alignment between the motor and pump spigot centres, the bell-housing cannot be disassembled and reassembled.

Machining tolerances

D1	F8
Spigot hole	H7
H1	± 0,15 mm

Concentricity of D1/Spigot hole

LMS 250	0,20 mm
LMS 300 - LMS 660	0,25 mm

TABLE 21

Electric motor, 4-pole, 1500 rpm				Dimensions of LMS low noise bell-housing										
Motor size	kW	Hp	Motor shaft	Bell-housing code	Foot bracket code	D1	D2	D3	H1	H2	F	Nr.	P	Nr.
100-112	2.2-4	3-5.5	28x60	LMS 250	PDM A 250	180	215	250	See tab. 22	19	M12	4	14	4
132	5.5-7.5	7.5-12.5	38x80	LMS 300	PDM A 300	230	265	300		23	M12	4	14	4
160	11-15	15-20	42x110	LMS 350	PDM A 350	250	300	350		31	M16	4	18	4
180	18.5-22	25-30	48x110	LMS 350	PDM A 350	250	300	350		31	M16	4	18	4
200	30	40	55x110	LMS 400	/	300	350	400		31	M16	4	18	4
225	37-45	50-60	60x140	LMS 450	/	350	400	450		31	M16	8	-	-
250	55	75	65x140	LMS 550	/	450	500	550		31	M16	8	-	-
280	75-90	100-125	75x140	LMS 550	/	450	500	550		31	M16	8	-	-
315	110-200	150-272	80x170	LMS 660	/	550	600	660		42	M20	16	-	-

To determine dimension H1 of the bell-housing
 For dimensions of the foot bracket
 For all other dimensions

see table 33
 see page 55
 see pump manufacturer's technical literature

LMS low noise bell-housing, dimension H1

TABLE 22

Pump flange			Pump flange			Pump flange		
Code	H1	Weight (kg)	Code	H1	Weight (kg)	Code	H1	Weight (kg)
LMS 250AFSA***	128	3,72	LMS 250AFRA***	158	3,97	LMS400AF6A***	288	10,00
LMS 250AFSB***	148	4,10	LMS 250AFRB***	165	4,10	LMS400AF6B***	289	10,10
LMS 300AFSC***	155	4,20	LMS 250AFRC***	168	4,30	LMS400AF6C***	301	10,25
LMS 300AFSD***	168	4,45	LMS 250AFRD***	171	4,60	LMS400AF6D***	314	11,10
LMS 300AFSE***	194	6,51	LMS 250AFRE***	173	4,70	LMS400AF6E***	326	11,70
LMS 350AFSF***	204	6,80	LMS 250AFRG***	181	5,10	LMS400AF6G***	338	11,90
LMS 350AFSG***	228	7,10	LMS 250AFRH***	183	5,70	LMS400AF6H***	342	12,10
LMS 350AFSH***	204	8,51	LMS300AFRA***	178	4,50	LMS400AF6L***	357	13,00
LMS 400AFSL***	228	8,80	LMS300AFRB***	185	4,75	LMS400AF6M***	396	15,70
LMS 400AFSM***	256	9,10	LMS300AFRC***	188	4,85	LMS450AF6A***	287	14,10
LMS 400FSN***	240	11,61	LMS300AFRD***	191	4,90	LMS450AF6B***	288	14,20
LMS 450FSO***	255	12,10	LMS300AFRE***	193	5,10	LMS450AF6C***	300	15,10
LMS 550FSP***	255	15,20	LMS300AFRG***	201	5,50	LMS450AF6D***	313	16,00
LMS 550FSR***	270	15,90	LMS300AFRH***	203	5,80	LMS450AF6E***	325	16,50
LMS 550FSS***	290	19,20	LMS300AF5A***	194	5,20	LMS450AF6G***	337	17,20
LMS 660FST***	305	20,20	LMS300AF5B***	198	5,50	LMS450AF6H***	341	17,50
			LMS300AF5C***	200	5,70	LMS450AF6L***	356	17,90
			LMS300AF5D***	203	5,90	LMS450AF6M***	395	19,00
			LMS300AF5E***	213	6,20	LMS550AF6A***	302	17,20
			LMS300AF5G***	232	6,70	LMS550AF6B***	303	17,20
			LMS300AF5H***	259	7,80	LMS550AF6C***	315	18,30
			LMS350AF5A***	254	8,10	LMS550AF6D***	328	19,00
			LMS350AF5B***	258	8,30	LMS550AF6E***	340	19,50
			LMS350AF5C***	260	8,50	LMS550AF6G***	352	19,90
			LMS350AF5D***	263	8,70	LMS550AF6H***	356	20,20
			LMS350AF5E***	273	9,00	LMS550AF6L***	361	20,45
			LMS350AF5G***	292	10,10	LMS550AF6M***	400	22,50
			LMS350AF5H***	319	11,30	LMS660AF6A***	337	23,00
						LMS660AF6B***	338	23,40
						LMS660AF6C***	350	24,50
						LMS660AF6D***	363	25,30

Specified tightening torques for auxiliary flange

- FR* 18 Nm
- F5* 100 Nm
- F6* 180 Nm

Recommended tightening torques for motor/pump assembly bolts

- M6 10 Nm
- M8 24 Nm
- M10 50 Nm
- M12 84 Nm
- M14 135 Nm
- M16 205 Nm
- M18 280 Nm
- M20 400 Nm
- M22 530 Nm
- M24 690 Nm

These values are calculated to exploit the performance of the bolt at 70% of its elastic limit.

This means in practice that the shank of the bolt will be stressed typically to 60-70% of its limit of elasticity in the course of being tightened.

The values indicated are valid for hexagon head bolts to UNI 5737 and hexagon socket screws to UNI 5931, property class 8.8, tightened by degrees using a torque wrench.

If bolts or screws are tightened using impact or hammer action drivers, the applied torque should be reduced by 10%.

Comparative table

MP Filtri	OMT	Raja	KTR
Code	Code	Code	Code
LMS250A***	BS251***	R250***DF	PK+D150/190
LMS300A***	BS301***	R300***DF	PK+D150/190
LMS350A***	BS351***	R350***DF	PK+D150/190/D230/260
LMS400A***	BS400***	R400***DF	PK+D190/D230/260
LMS450A***	BS451***	R450***DF	PK+D190/230/D260/330
LMS550A***	BS551***	R450***DF	PK+D190/230/D260/330
LMS660A***	BS661***	R450***DF	PK+D190/230/D260/330

Note: The above table is guideline only.

Not all bell-housings are fully interchangeable.

For further information, contact the MP Filtri Technical and Sales Department.

A guide to select the correct bell-housing and drive coupling components

DATA REQUIRED

Electric motor power/motor size
Manufacturer and pump type

TO VERIFY:

- 1 - Pump and motor shaft dimensions (see page 69)
- 2 - Shaft and flange pump (see pump data sheet)

Example:

- Electric motor 2 kW - 4 poles - Motor size 110/112
- Atos pump code PFE31 - Shaft 1

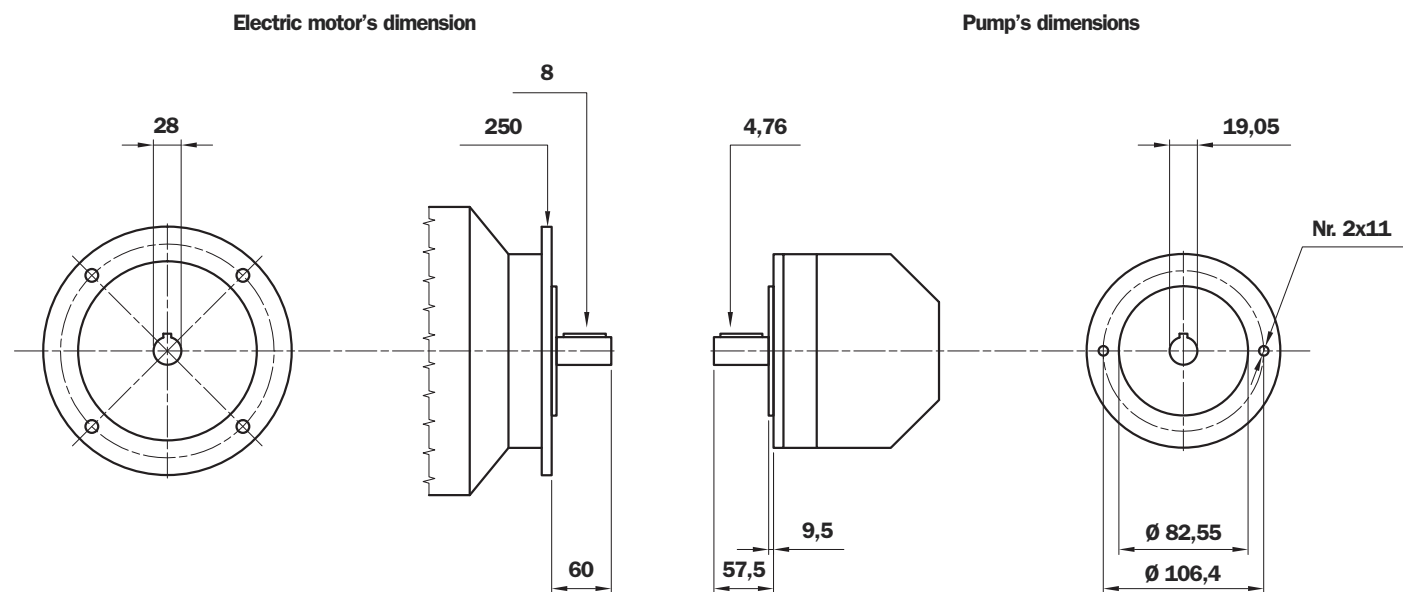

Bell-Housing's length calculation

- $H = 60 + 18 + 57,5 = 135,5$ mm (18= Sp spider - see page 49)
- Choose type of bell-housing (LMC - LMS)
 - For LMC see tab. 3 at page 11
 - For LMS see tab. 21 at page 32
 - For MODUL 2/3 see at page 36

Note: The length of bell-housing must be \geq than the length calculated (135,5 mm)

Case A - solution with LMC bell-housing

Tab. 3 at page 11 - for electric motor 2kW LMC 250
LMC 250 bell-housing with height $\geq 135,5$ - LMC250AFSQ

- The bell-housing code must be completed with drilling pump code (see tab. 34 at page 47)
For the specific case C= 101,6 - Nr. 2 holes M10: Code drilling 070
- Definitive bell-housing code **LMC250AFSQ070**

Case B - solution with LMS bell-housing

Tab. 21 at page 32 - for electric motor 2kW LMS 250
LMS 250 bell-housing with height $\geq 135,5$ - LMS250AFSQ

- The bell-housing code must be completed with drilling pump code (see tab. 34 at page 47)
For the specific case C= 101,6 - Nr. 2 holes M10: Code for. 070
- Definitive bell-housing code **LMS250AFSQ070**

Choose coupling

- **Motor half-coupling** (see tab. 37 at page 50)
 - For electric motor GR 100/112, the half-coupling is **SGEA21M05060**
- **Spider** (see tab. 35 - 36 at page 49)
 - For SGEA21, EGE2 - EGE2RR
(choose spider material on the base of the application, oil, temperature and cycle machine, etc.)
- **Pump half-coupling**
 - Choose the drilling code tab. 43 - 44 at page 53 for shaft 19,05 - Ch. 4,76 - code: **G01**
 - Half-coupling length = L BH length - THK Spider - THK Spigot
 $138 \text{ mm} - 60 - 18 - 9,5 = 50,5 \text{ mm}$
 - Choose the half-coupling's length on tab. 38 at page 50 $\leq 50,5 \text{ mm}$.
 - Available length for SGEA21= 50 mm
 - Code half-coupling code: **SGEA21G01050**

**Software for automatic calculation available on the web site
www.mpfiltri.com - tools - software**

The screenshot shows the MP Filtri software interface for pump and motor selection. The interface is divided into several sections:

- HYDRAULIC PUMP - Technical Data:**
 - AKA: AKM0320068
 - Manufacturer: ATOS
 - Pump type: PFE
 - Pump model: PFE31 Shaft 1
 - Technical Data: L1: 57.5, d1: 19.05, Ch1: 4.76, E: 9.5, H1: 82.55, B1: 106, W: 2, F: M20
- ELECTRIC MOTOR - Technical Data:**
 - N. Pole: 2P
 - Type: M3-B5
 - Size: 100-112
 - Sec: 3-4
 - tp: 4-5,44
 - Technical Data: L1: 60, H1: 28, Flg: 256, Ch: 8
- Coupling material:**
 - Aluminium
 - Cast iron
 - Allow alternative material
- Result:**
 - Coupling: M01 - 21066
 - Drilling Pump: 5000
 - Pump Shaft: G01
 - Motor Shaft: M01
 - Monobloc Bellhousing: OK
 - Modular Bellhousing: Not OK
 - Silenced Bellhousing: Not OK

Additional text in the result section: "Pump half-coupling with grub screw. For other solution please contact technical department."

Button: **CLICK HERE TO PROCEED**

Note: For multi pumps we recommend to use a specific support on the base of the pump's dimensions and weight.

Half-coupling SGE*** series

The half-couplings series SGE*** allow secure transmission between the electric motor and the driven side; they are able to absorb shocks and vibration, in addition to compensating radial misalignment, angular and axial.

The assembly of the couplings can be horizontal/vertical, withstanding vibration and load reversals.

The complete range of couplings are extrapolated from the on-line software, with a length equal than the shaft on which must be mounted and they are completed with grub screw for fixing located on the key.

Available for cylindrical shaft with metric and imperial dimensions as well for splined shafts as per specification DIN, ISO and SAE.

Admissible misalignment radial, angular and axial

Max admissible radial misalignment

Half coupling	R (mm)
SGE * 01	0,5
SGE * 21	1,0
SGE * 31	1,0
SGE * 40	1,0
SGE * 51	1,5
SGE * 60	1,5
SGE * 80	2,0
SGE * 90	2,0

Max admissible angular misalignment

Half coupling	β (°)
SGE * 01	
SGE * 21	
SGE * 31	
SGE * 40	1,5°
SGE * 51	
SGE * 60	
SGE * 80	
SGE * 90	

Max admissible angular misalignment

Half coupling	A (mm)
SGE * 01	2,0
SGE * 21	2,5
SGE * 31	3,0
SGE * 40	3,5
SGE * 51	3,5
SGE * 60	3,5
SGE * 80	4,0
SGE * 90	5,0

Normative ATEX 94/9/CE

Half-couplings SGE*** series are available to use in hazardous area.

The couplings are certified according to ATEX 94/9/CE (ATEX 95).

Category certified 2G - area 1 and 2.

Other information available on our web site "www.mpfiltri.com".

MP Filtri couplings are developed with:

CAD 3D



FEM (calculation)



Drawings 3D available on website www.mpfiltri.com at section TOOLS/2D-3D COMPONENTS

The half-couplings SGE*** series are in conformity to normative **DIN 740/2**.
The max torque to transmit is always less than the max torque that the coupling can transmit.

Examples verification of the coupling

Torque transmitted by electric motor:

Mt: $9560 \times \text{kW} / \text{rpm} = \text{Nm}$

Me > $\text{Mt} \times \text{S} = \text{Nm}$

Where:

Mt: Torque transmitted by electric motor

Me: Torque transmitted by coupling (see table 14)

kW: Power of electric motor

Rpm: Revolutions per minute of electric motor

S: Service factor (see table 14)

TABLE 1

Small pumps, uniform load, low operating pressures e.g. rotary action machine tools - 5/8 work cycles per hour	1.3
Small pumps, uniform load, high working pressures e.g. lifting equipment - 120-150 work cycles per hour	1.5
Pumps, non-uniform load e.g. lifting equipment - 280-300 work cycles per hour	1.7

Example

Electric motor, 4 pole - 4 kW

hydraulic pump, uniform load, low operating pressure

Mt: $9560 \times 4 / 1500 = 25.45 \text{ Nm}$

Me > $25.49 \times 1.3 = 33 \text{ Nm}$

Half-coupling SGEA21 meets the above requirement.

Select the half-coupling of the calculated size from the motor half-couplings table.

Note: When selecting the coupling, remember that for pumps with splined shaft, only cast iron couplings of the SGEG series can be used.

Determine the size of the coupling according to the type of installation and application envisaged, on the basis of the following formulas and tables:

TABLE 2

Half-coupling type	External diameter mm	Nominal torque Me - Nm	Maximum transmissible torque Me - Nm	
ALUMINIUM	SGEA01	43	15	20
	SGEA21	68	160	190
	SGEA31	85	340	380
	SGEA51	109,5	550	620
CAST IRON	SGEG01	40	20	30
	SGEG30	80	400	450
	SGEG40	95	550	620
	SGEG60	120	760	850
	SGEG80	160	2200	2500
	SGEG90	200	5500	6100
STEEL	SGES40	95	550	620
	SGES60	120	760	850
	SGES80	160	2200	2500

Nominal and maximum torque values are referred to couplings assembled with standard flexible spiders of the **EGE**** series (see page 49).

Where higher torques are to be transmitted, use flexible spiders of the **EGE**RR** series (see page 49).

Noise

Noise is a particularly pervasive problem so much so that there have been statutory regulations in place now for some years, designed to limit harmful occupational exposure. Many of the machines used in industry today are equipped with oil-hydraulic systems, which happen to be a major source of noise.

1. Theory and definition of noise

From a health and hygiene standpoint, noise can be defined as an unpleasant and undesirable sound, or an unpleasant and annoying or intolerable auditory sensation (noise being any sound phenomena that may be accompanied by sensations of disturbance and pain). By definition, acoustic phenomena are oscillatory in character, propagated in a flexible medium and causing pressure variations at the points, and the areas adjacent to those points, through which they pass.

2. Sound

Technically considered, certain elements must be present simultaneously for acoustic phenomena to occur:

- Sound source
- Transmission medium
- Receiver

Motor and pump unit

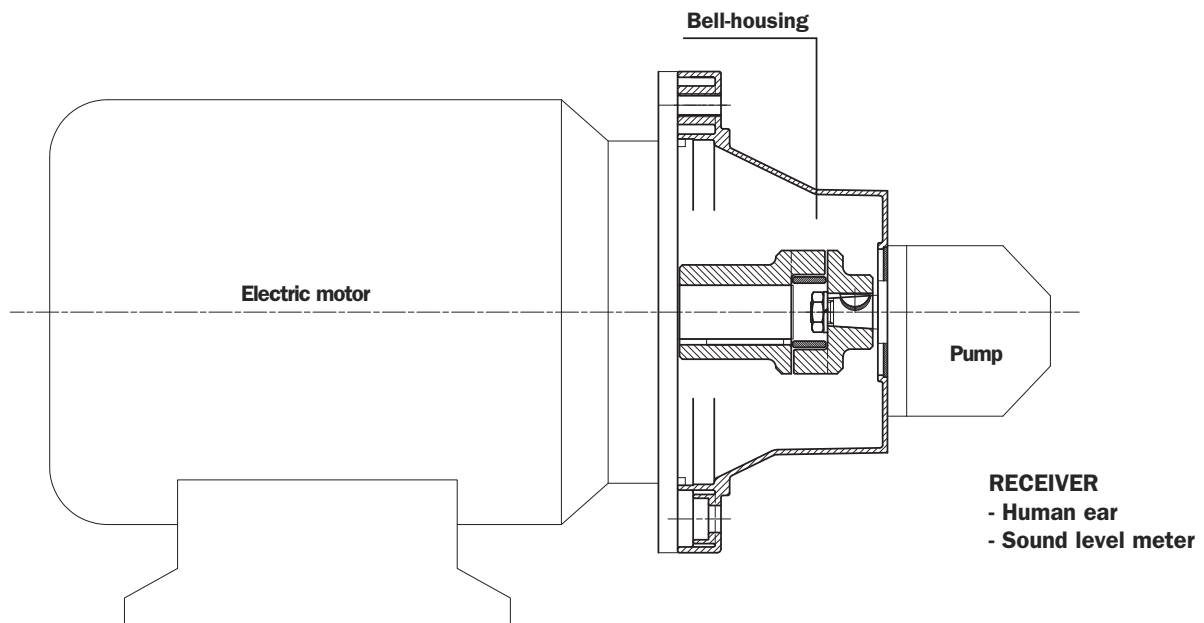

The **electric motor** and the **pump**, together with the drive coupling, are the **SOURCE OF THE NOISE**.

The **Bell-housing** is the noise transmission medium.

Depending on whether the monobloc bell-housing is a rigid or low noise type, there will be variations in the flexible properties of the transmission medium.

The acoustic phenomena are dissimilar in the two cases, given the differences in pressure variation and particle displacement.

Assembly of motor and pump unit

As mentioned in the presentation, low noise bell-housing will help to attenuate the transmission of vibrations and the emission of noise generated by the system.

Self-evidently, however, the mere adoption of a low noise bell-housing will achieve little unless the motor and pump are correctly installed on the machine, or on the tank of the hydraulic power unit.

- Should be followed in order to achieve best possible results and correct installation:

1. Motor and pump unit mounted horizontally on oil tank lid

- The suction pipe attached to the pump must be rigid, and fitted using a resilient bulkhead flange of the FTA series, which helps to cushion the vibrations propagated between the pipe and the tank lid. If pipes need to be bent, the radius of curvature must be at least 3 times the pipe diameter. Do not use elbow fittings, as these will significantly increase pressure losses.
- The pressure pipeline of the pump must be flexible, and long enough to include bends with the minimum radius of curvature recommended by the manufacturer for the specified operating pressure.
- The return pipeline running from the service to the filter must be flexible. Where oil is returned directly to the tank of the hydraulic power unit through a rigid pipe, it is advisable to use a resilient bulkhead flange of the FTR series, which helps to cushion the vibrations propagated between the pipe and the tank lid.
- Anti-vibration devices (resilient mounts or damping rods) must be located under the feet of the electric motor or the PDM foot brackets, depending on the mounting position of the motor.
- The lids of hydraulic oil tanks must be sturdy enough to support the load they carry.

2. Motor and pump unit mounted horizontally on machine

- As a matter of good practice, the oil tank and motor-pump unit should be mounted on a single supporting frame of strength sufficient to support the load.
- If the hydraulic system is fitted with a side-mounted filter, the suction pipeline to the pump must be flexible, and long enough to include bends with the minimum radius of curvature recommended by the manufacturer.
- If the suction filter is not side mounted, the pipeline should be rigid and installed in conjunction with a compensating coupling.
- The pressure pipeline of the pump must be flexible, and long enough to include bends with the minimum radius of curvature recommended by the manufacturer for the specified operating pressure.
- The return pipeline running from the service to the filter must be flexible. Where oil is returned directly to the tank of the hydraulic power unit through a rigid pipe, it is advisable to use a resilient bulkhead flange of the FTR series, which helps to cushion the vibrations propagated between the pipe and the tank lid.
- Anti-vibration devices (resilient mounts or damping rods) must be located under the feet of the electric motor or the PDM foot brackets, depending on the mounting position of the motor.

Note: The above guidelines are indicative only, and subordinate to the solutions adopted ultimately by design engineers.

In conclusion: For best results, in any event, the motor-and-pump unit should be incorporated into the hydraulic system in such a way that no one component is rigidly associated with another, resulting in the propagation of vibration, and consequently noise.

Table of summary MODUL 2/3

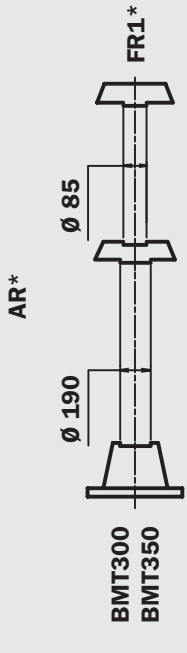
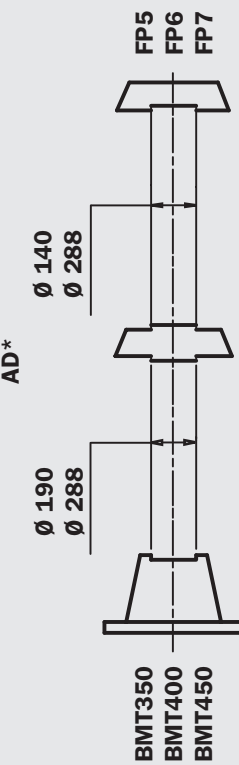
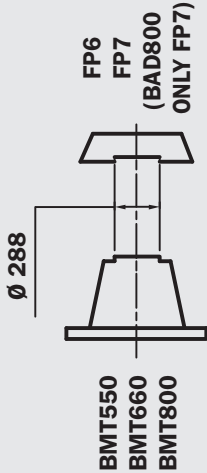
	5.5 - 7.5 kW	11 - 22	30	37 - 45	55 - 90	110 - 200	250 - 400
	7.5 - 10.2 Hp	15 - 30 Hp	40.80 Hp	50.32 - 61.2 Hp	75 - 125 Hp	150 - 272 Hp	340 - 544 Hp
	Size 225 - D.450	Size 160/180 D.350	Size 200 - D.350	Size 225 - D.450	Size 250/280 D.550	Size 315 - D.660	Size 355/400 D.800
MODUL 2	 <p>AR*</p> <p>BMT300 BMT350</p> <p>FR1*</p> <p>Kit of assembly KVG5 (Q.ty 1) + Kit of assembly KVG1 (Q.ty 1)</p>						
	 <p>AD*</p> <p>BMT350 BMT400 BMT450</p> <p>FP5 FP6 FP7</p> <p>Kit of assembly KVG5/7 (Q.ty 2)</p>						
MODUL 3	 <p>Kit of assembly KVG6/7 (Q.ty 1)</p> <p>BMT550 BMT660 BMT800</p> <p>FP6 FP7 (BAD800 ONLY FP7)</p>						
	5.5 - 7.5 kW	11 - 22	30	37 - 45	55 - 90	110 - 200	250 - 400
7.5 - 10.2 Hp	15 - 30 Hp	40.80 Hp	50.32 - 61.2 Hp	75 - 125 Hp	150 - 272 Hp	340 - 544 Hp	
Size 225 - D.450	Size 160/180 D.350	Size 200 - D.350	Size 225 - D.450	Size 250/280 D.550	Size 315 - D.660	Size 355/400 D.800	

Modular bell-housing components

MODUL 2/3

Modular bell-housing components are used to connect **UNEL-MEC electric motors with B3 - B5** flanges to piston, vane and screw type hydraulic pumps.

The advantage of modular design is that a wide range of motor and pump combinations can be covered with relatively few components.

This means that dealers can simplify their inventory while still being able to service the majority of applications envisaged.

The strength of these components will also guarantee top reliability, even in the toughest of applications.

Suitable for electric motors from **size 132, rated 5.5 kW**, up to **size 400, rated 400 kW**.

Technical specifications

MODUL 2/3

Materials

- **Base module**
Pressure diecast aluminium alloy.
- **Pump flange**
Alluminium alloy.
- **Intermediate adapter**
Alluminium alloy.
- **Foot bracket**
Pressure diecast aluminium alloy.
- **Gaskets**
Special paper (guarnital).

Temperature

- $-30^{\circ}\text{C} \div +80^{\circ}\text{C}$
For temperatures outside this range,
contact the MP Filtri Technical and Sales Department.



Compatibility with fluids

- **Modular bell-housing components compatible for use with:**

Mineral oils

Types HH-LL-HM-HR-HV-HC, to ISO 6743/4 standard

Water based emulsions

Types HFAE - HFAS, to ISO 6743/4 standard

Water glycol

Type HFC, to ISO 6743/4 standard

Ask for anodized version

Special Applications

- **Any applications not covered by the normal indications contained in this catalogue must be evaluated and approved by the MP Filtri Technical and Sales Department.**

Mounting components

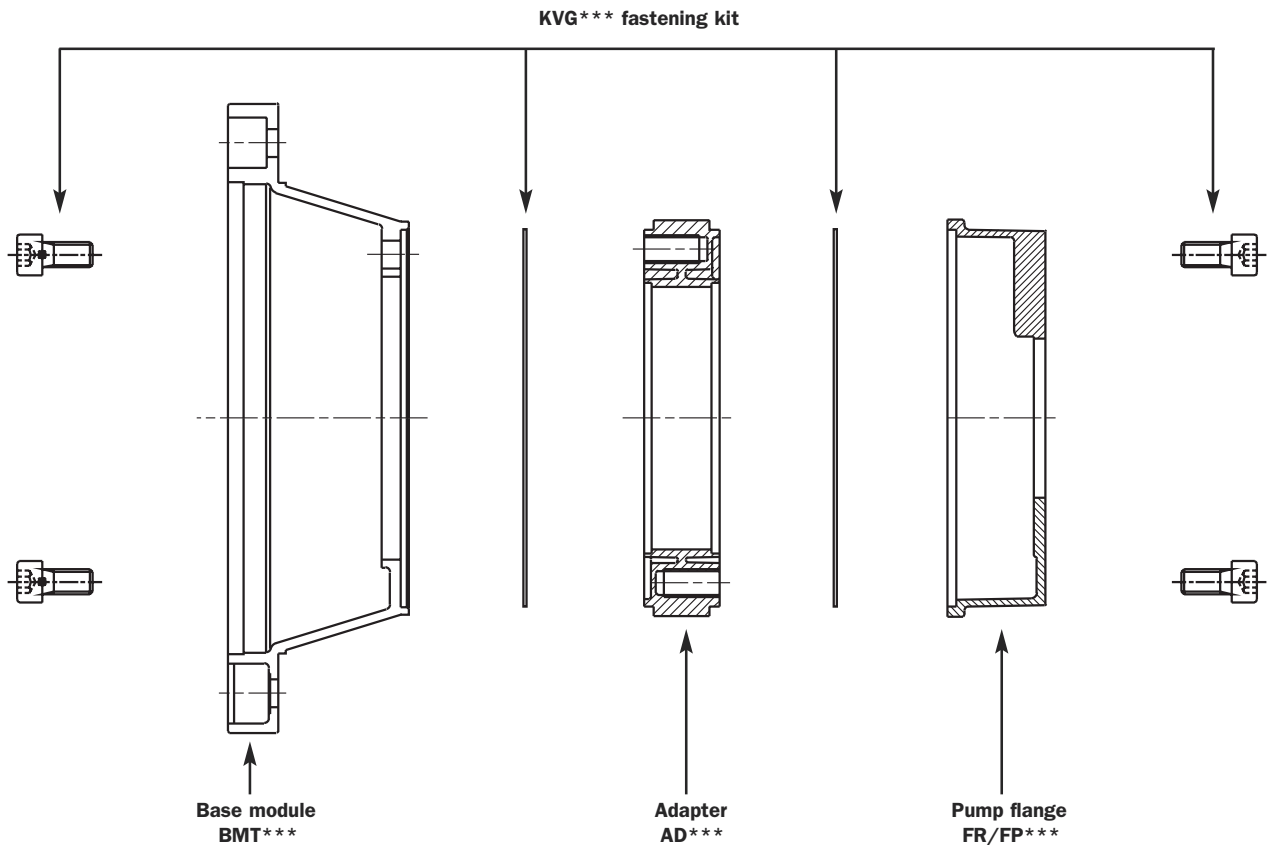

- 1 Clean the gasket seating surfaces
- 2 Locate the base module gasket in the relative recess and position the adapter
- 3 Secure with the bolts of the kit
- 4 Locate the pump flange gasket in the relative recess, then offer the flange to the adapter
- 5 Secure with the bolts of the kit

Note: Secure the screws of the fastening kit as indicated in the following table

Recommended tightening torques for assembly of components.

KVG 1	KVG 5	KVG 6	KVG 7
M8	M14	M16	M20
24 Nm	135 Nm	205 Nm	400 Nm

These values are calculated to exploit the performance of the bolt at 70% of its elastic limit.

This means in practice that the shank of the bolt will be stressed typically to 60-70% of its limit of elasticity in the course of being tightened.

The values indicated are valid for hexagon head bolts to UNI 5737 and hexagon socket screws to UNI 5931, property class 8.8, tightened by degrees using a torque wrench.

If bolts or screws are tightened using impact or hammer action drivers, the figure indicated should be reduced by 10%.

.....

.....

.....

.....

.....

.....

.....

.....

Motor base

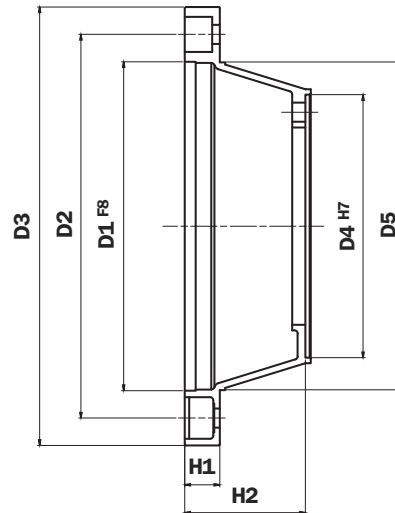
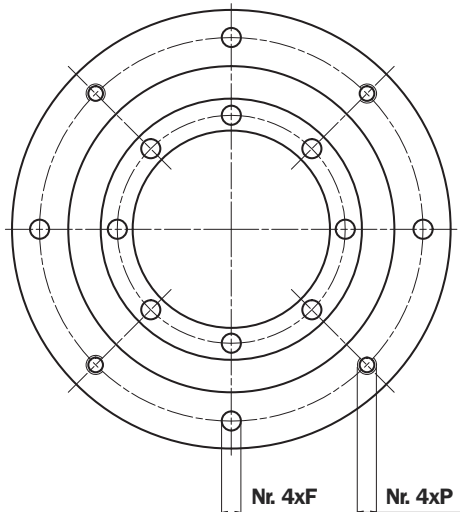

TABLE 23 - MODUL 3

Motor 4-pole 1500 rpm				Dimensions of motor base													
Frame size	kW	Hp	Shaft	Code	Foot bracket code	D1	D2	D3	D4	D5	H1	H2	F.	Nr.	P	Nr.	Weight (kg)
132	5.5-7.5	7.5-12.5	38x80	BMT300A0805	PDM A 300	230	265	300	190	234	24	80	M12	4	14	4	1,95
160	11-15	15-20	42x110	BMT350A1105	PDM A 350	250	300	350	190	260	32	110	M16	4	18	4	3,10
180	18.5-22	25-30	48x110	BMT350A1105	PDM A 350	250	300	350	190	260	32	110	M16	4	18	4	4,90
200	30	40	55x110	BMT400A1106	/	300	350	400	240	300	32	110	M16	4	18	4	4,90
225	37-45	50-60	60x140	BMT450A1406	/	350	400	450	240	350	32	140	M16	8	/	/	5,00

For dimension see page 55

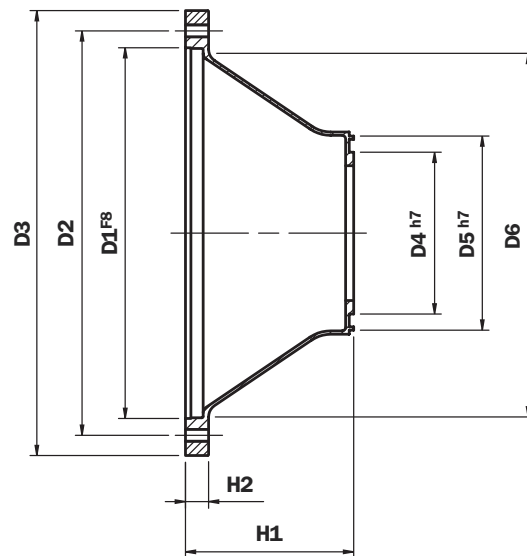
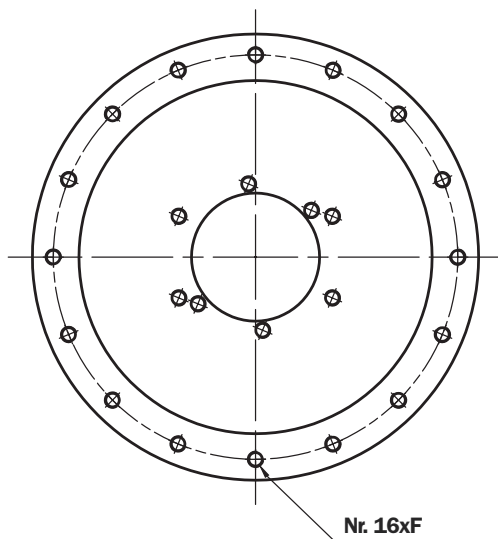

TABLE 24 - MODUL 2

Motor 4-pole 1500 rpm				Dimensions of motor base														
Frame size	kW	Hp	Shaft	Code	Foot bracket code	D1	D2	D3	D4	D5	D6	H1	H2	F.	Nr.	P	Nr.	Weight (kg)
250	55	75	65x140	BMT550A21567	/	450	500	550	240	288	450	215	32	M16	16	/	/	8,40
280	75-90	100-125	75x140	BMT550A21567	/	450	500	550	240	288	450	215	32	M16	16	/	/	8,40
315	110-200	100-125	80x170	BMT660A25067	/	550	600	660	240	288	550	250	40	M20	16	/	/	12,00
355	250-315	340-428	95x170	BAD800A2707	/	680	740	660	288	/	680	270	40	M20	8	/	/	31,00
400	355-400	483-544	100x210	BAD800A2707	/	680	740	800	288	/	680	270	40	M20	8	/	/	31,00

Not available

Intermediate adapter

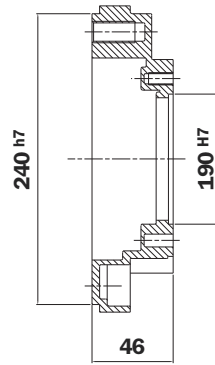

TABLE 25

Application with Motor base	Application with Pump Flange	Code Adapter	Fastening kit Motor base	Fastening kit Pump Flange	Weight (kg)
BMT400A1106 BMT450A1406	FP6 *** **	AD60465	KVG6	KVG5	1,30

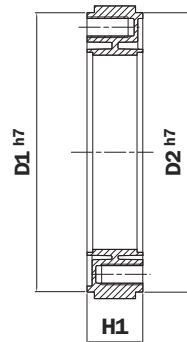

TABLE 26

Application with Motor base	Application with Pump Flange	Code Adapter	Fastening kit Motor base	Fastening kit Pump Flange	D1	D2	H1	Weight (kg)
BMT300A0805 BMT350A1105	FP5 *** **	AD50385	KVG5	KVG5	190	240	38	1,00
BMT400A1106 BMT450A1406	FP6 *** **	AD60466	KVG6	KVG6	240	288	46	1,60

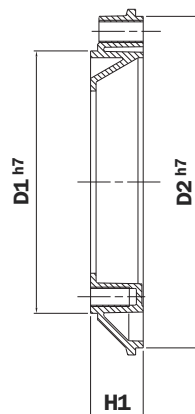

TABLE 27

Application with Motor base	Application with Pump Flange	Code Adapter	Fastening kit Motor base	Fastening kit Pump Flange	D1	D2	H1	Weight (kg)
BMT300A0805 BMT350A1105	FP5 *** **	AD50386	KVG5	KVG6	190	240	38	1,25
BMT300A0805 BMT350A1105	FP5 *** **	AD50467	KVG5	KVG7	190	288	46	1,90
BMT400A1106 BMT450A1406	FP6 *** **	AD60467	KVG6	KVG7	240	288	46	2,50

Pump flange

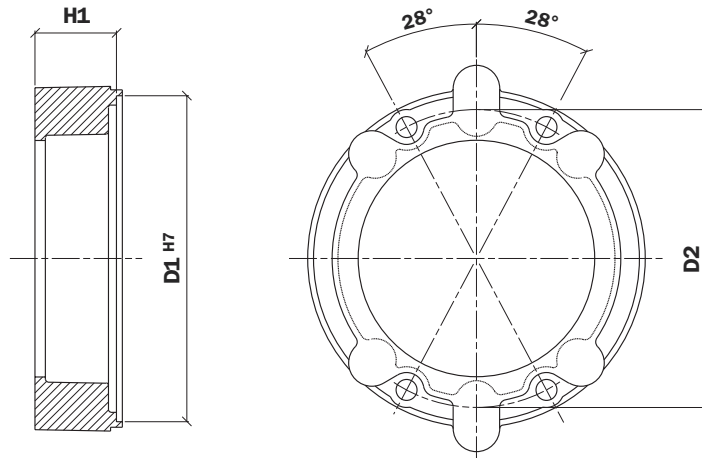

TABLE 28

Code	Flange			Assembly kit	Possible pump interfaces	Weight (kg)
	H1	D1	D2			
FR1023***	23	85	105	KVG1	S024 S025 D042 S061 S063 S083 S023 S070 S071 S072 S075 S125 S154	0,25
FR1025***	25				S021 S026 S068 S069 S080 S082 S115 S237	0,30
FR1033***	33				S021 S023 S026 S027 S070 S071 S072 S074 S080 S082 F260	0,80
FR1035***	35				S060 S063 S065	0,90
FR1040***	40				S098 S227	1,10
FR1079***	79				S031 S116	1,30

TABLE 29

Code	Flange			Assembly kit	Possible pump interfaces	Weight (kg)			
	H1	D1	D2						
FP5026***	26	190	170	KVG5	S023-S024-S025-S033-D042-S063-S070-S072-S075-S154-S254	1,00			
FP5032***	32				S024-S031-S158-S096-S125	1,10			
FP5035***	35				S021-S023-S024-S025-S026-S031-S059-S060-S068-S072-S074-S075-S083-S097-S106-S125-S131-S138	0,90			
FP5045***	45				S021-S024-S025-S026-S060-S068-S070-S071-S072-S074-S075-S106-S125-S141	0,90			
FP5056***	56				S021-S026-S072	1,61			
FP5063***	63				S021-S025-S068-S070-S079-S138-S141	1,70			
FP5064***	64				S024-S025-S059-S093-S099-S100-S104	1,70			
FP5091***	91				S025-S031-S033-S100-S113-S115-S116-S267	2,20			
FP6032***	32				240	218	KVG6	S021-S035-S081-S082	1,80
FP6045***	45	S021-S025-S026-S027-S069-S070-S075-S077-S080-S081-S082-S125-S198-S207-S215-S253	2,10						
FP6058***	58	S024-S025-S026-S027-S038-S077-S078-S079-S080-S081-S082-S207-S215-S237	2,40						
FP6070***	70	S080-S270	3,00						
FP6082***	82	S038-S080-S081-S116-S141-S198-S215	3,30						
FP6086***	86	S021-S026-S027-S077-S078-S090-S092-S166-S091-S114-S132-S198-S200	3,40						
FP6101***	101	S027-S035-S113-S115-S132-S148-S176-S228	4,20						
FP6110***	110	S080-S111	5,50						
FP7052***	52	288	258	KVG7				S028-S092-S108-S112-S133-S192	4,10
FP7066***	66							S090-S092-S166	4,75
FP7069***	69				S108-S143-S148-S158-S192-S19-S201-S204-S281-S282-S288	4,90			
FP7086***	86				S022-S027-S028-S091-S092-S108-S112-S117-S166-S184-S192-S201-S228-S300	5,20			
FP7111***	111				S028-S091-S112-S117-S144-S145-S184	6,30			

Complete the order designation with the pump interface code: Ex. **FP5026S023**

Monobloc bell-housing for NEMA motors

Monobloc bell-housings for NEMA motors are standard products of the LMC series used normally for electric motors manufactured to European standards.

These bell-housings must be used in combination with specific **ADNEMA 143 TD** and **ADNEMA 254 TD** adapters.

For dimensions and clearances of adapter rings see page 45.

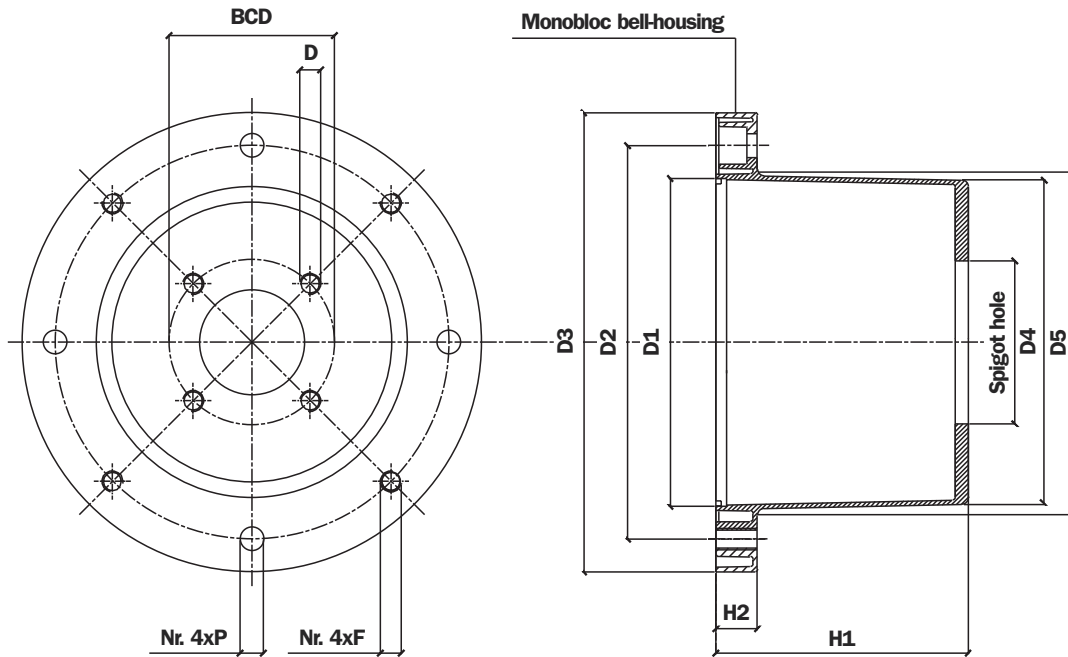

The auxiliary flange, if specified, is supplied already fitted to the bell-housing (MODUL-2).

- Check that the pump interface dimensions are compatible with those of the bell-housing

Note: The hole made in the tank cover should be 2 mm larger than dimension D5

Machining tolerances

D1	F8
Spigot hole	H7
H1	± 0,15 mm

Concentricity of D1/Spigot hole

LMC 300	0,20 mm
---------	----------------

TABLE 30

Bell-housing code	Dimensions of LMC monobloc bell-housing									
	Foot bracket code	D1	D2	D3	D4	D5	H1	H2	F	P
LMC 300AFST***	PDM A 300	230	265	300	230	235	155	23	M12	14
LMC 300AFSX***	PDM A 300	230	265	300	230	235	170	23	M12	14
	For dimension see page 55									

Base module for NEMA motors

BMC series motors base are derived from standard LMC monobloc bell-housings and used as base elements to which **FR/FP5/FP6** series auxiliary flanges can be fixed so as to increase the height of the bell housing or allow the attachment of a pump, which would not be possible using a monobloc bell housing.

Motors base can be used for the installation of NEMA motors in conjunction with specific **ADNEMA 143 TD** and **ADNEMA 254 TD adapters**. For dimensions and clearances of adapter rings, see page 45.

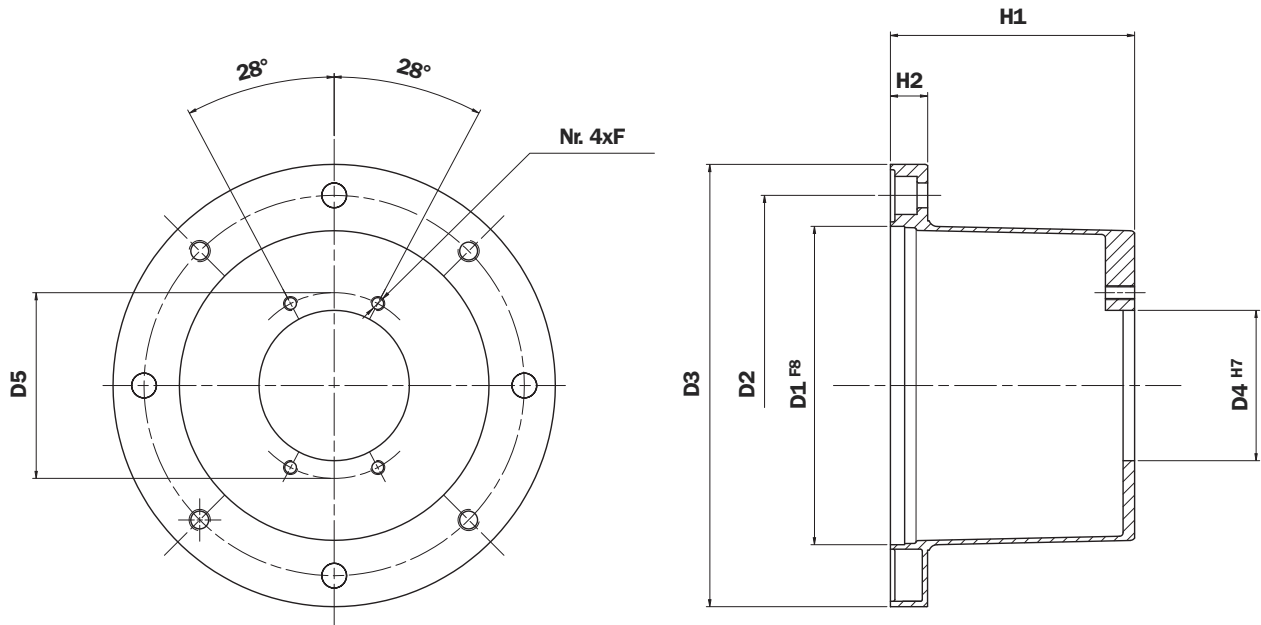

TABLE 31

		Dimensions of BMC motor base								Weight (kg)
Motor base code	Foot bracket code	D1	D2	D3	D4	D5	H1	H2	F	
BMC300A1551	PDM A 300	230	265	300	85	105	155	23	M8	3,30
BMC300A1701	PDM A 300	230	265	300	85	105	170	23	M8	3,30
BMC300A1555	PDM A 300	230	265	300	170	218	155	23	M14	3,30
BMC300A1705	PDM A 300	230	265	300	170	218	170	23	M14	3,30

For dimension see page 55

• For pump flange codes, see page 17

Low noise bell-housing for NEMA motors

Low noise bell-housings for NEMA motors are standard products of the LMS series used normally for electric motors manufactured to European standards.

These bell-housings must be used in combination with specific **ADNEMA 143 TD** and **ADNEMA 254 TD** adapters. For dimensions and clearances of adapter rings, see page 45.

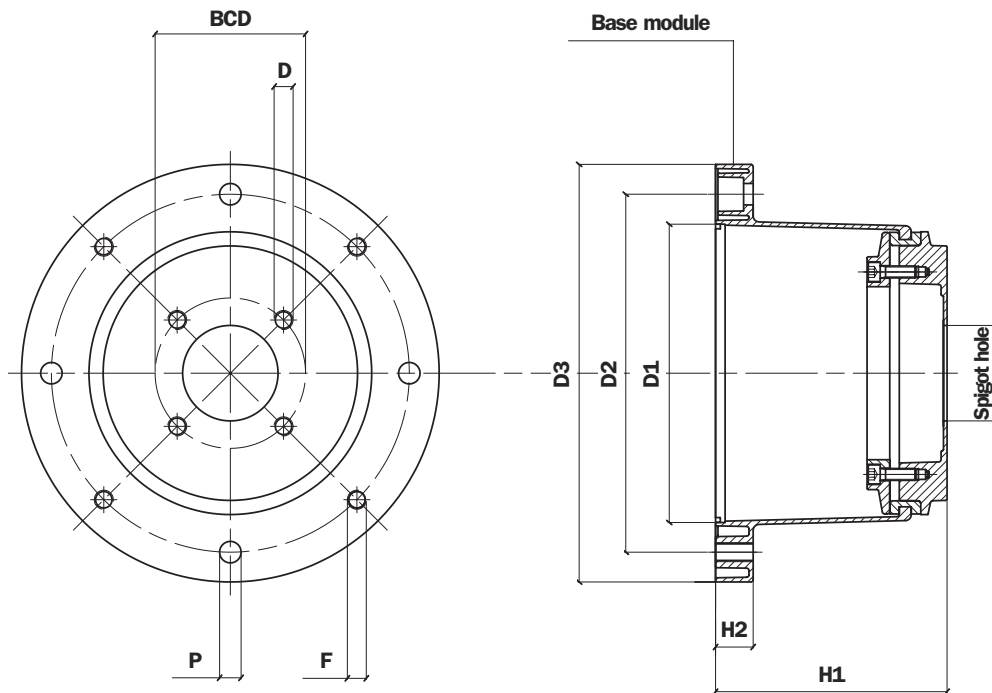

- The auxiliary flange, if specified, is supplied already fitted to the bell-housing.

N.B. In order to ensure coaxial alignment between the motor and pump spigot centres, the bell-housing cannot be disassembled and reassembled.

Machining tolerances

D1	F8
Spigot hole	H7
H1	± 0,15 mm

Concentricity of D1/Spigot hole

LMS 300	0,20 mm
---------	---------

TABLE 32

Dimensions of LMS low noise bell-housing								
Bell-housing code	Foot bracket code	D1	D2	D3	H1	H2	F	P
LMS 300AFSC***	PDM A 300	230	265	300	155	23	M12	14
LMS 300AFSD***	PDM A 300	230	265	300	168	23	M12	14

For dimension see page 55

Motor base for NEMA motors - Flange TD

Motors base for NEMA motors are standard products of the BMT series used normally for electric motors manufactured to European standards, which are machined in such a way as to provide the necessary interface for the NEMA motor. Motors base are utilized in conjunction with standard pump flanges of the FP series. For the dimensions of flanges, see page 17.

**Motor base for NEMA motors:
404TD - 405TD - 444TD - 445TD - 447TD - 449TD**

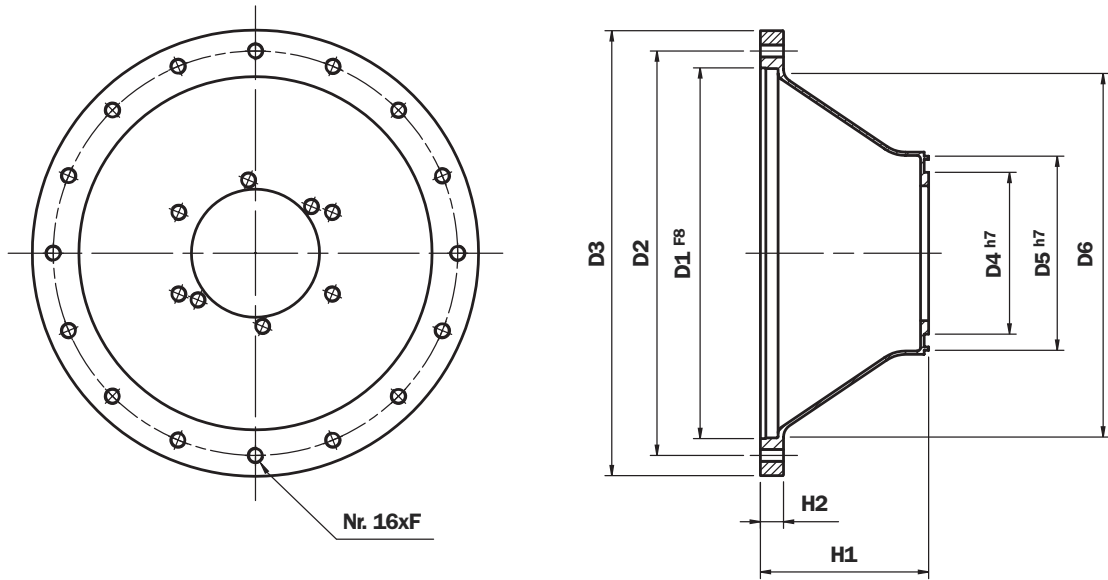
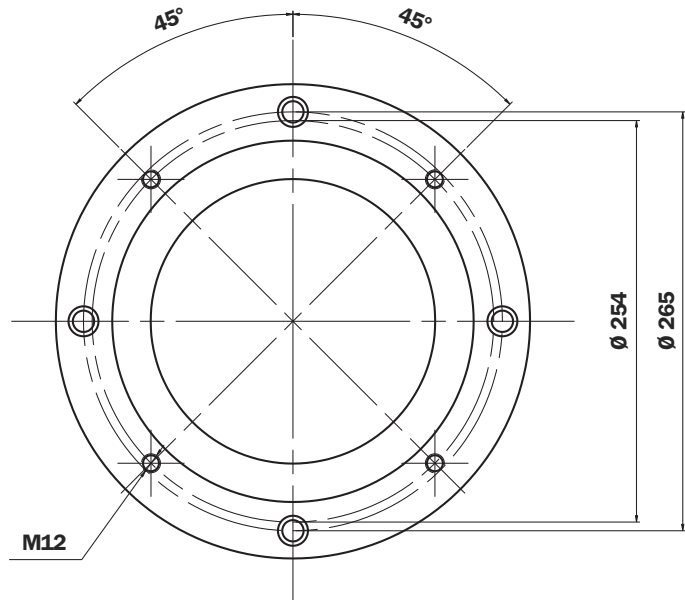
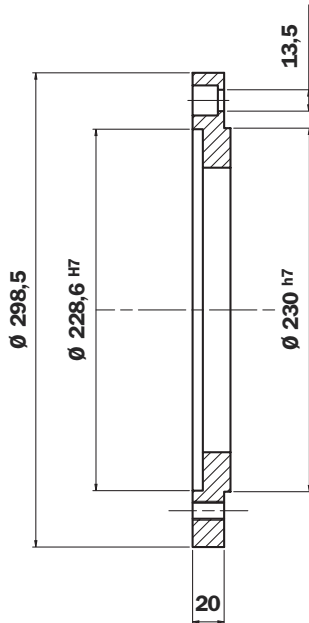

TABLE 33 - MODUL 2

Dimensions of Motor base										
Code	D1	D2	D3	D4	D5	H1	H2	F.	Nr.	Weight (kg)
BMT450NEMA324TD	355,6	406,4	450	240	350	140	32	18	8	5,00
BMT550NAMA404TD	457,2	508	550	240	450	215	32	18	16	8,40

Adapters for NEMA motors - Flange TD

Adapter for NEMA motors NEMA: Cod. ADNEMA143TD
143TD - 145TD - 180TD - 182TD - 184TD - 210TD - 213TD - 215TD
To assemble on bell-housing LMC - BMC - LMS - BMT 300



Adapter for NEMA motors NEMA: Cod. ADNEMA254TD
256TD - 284TD - 286TD

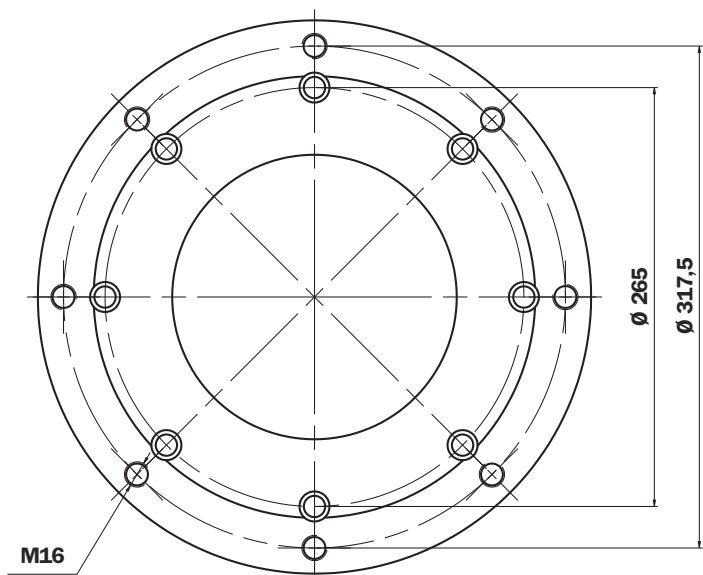
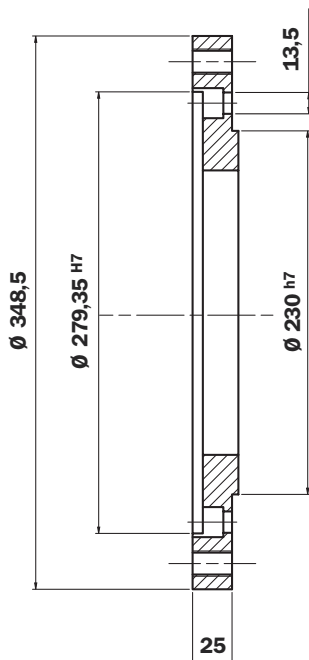

LMC series steel bell-housings

These bell-housings made of welded steel are available for electric motors rated from 0.5 up to 1000 kW, responding to UNEL-MEC (European) and to NEMA (US) standards. The dimensions can be customized to suit the type of motor-pump combination, or to meet particular customer specifications.

Standard finishes:

- zinc-treated, white
- oil-resistant primer, black

Custom treatments or paint finishes can be applied on request.

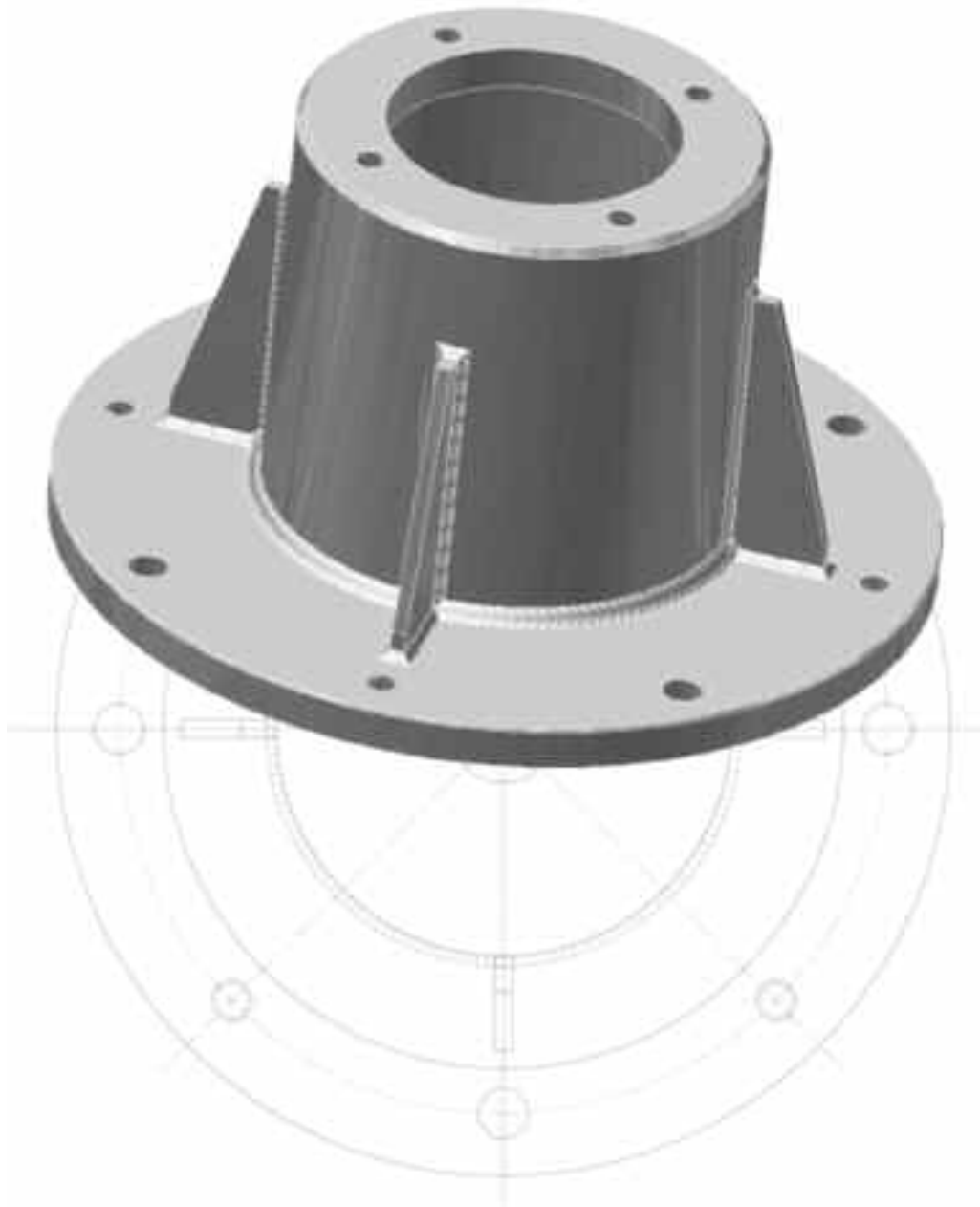
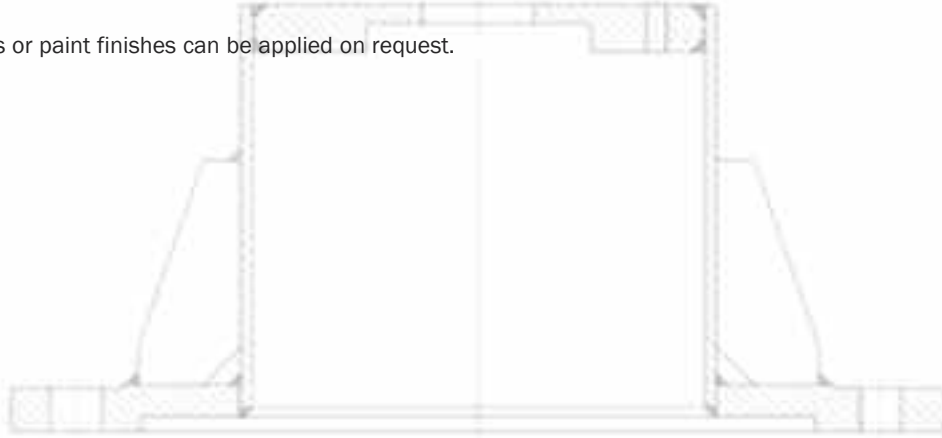

Pump interface codes

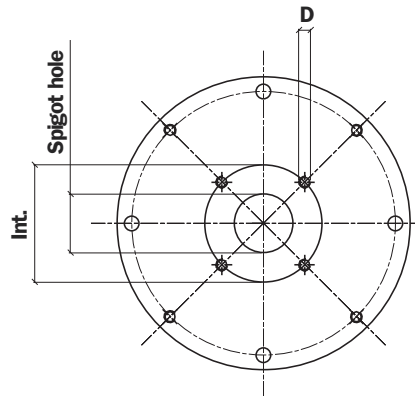
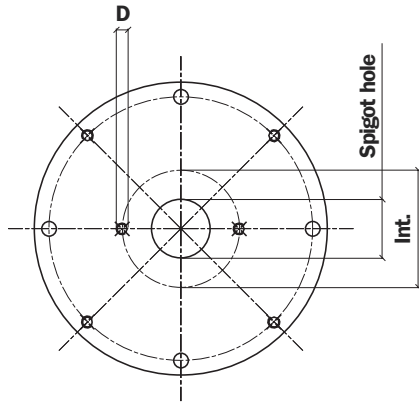

• 2 x hole at pump interface, aligned with through holes at motor interface

• 4 x hole at motor interface, aligned with through holes at motor interface

TABLE 34

Spigot hole mm	BCD	D	N° holes	Code
40	72	M8	2	191
45,2	88,9	M8	4	096
	71,8	M8	4	120
50	80	M8	2	052
	93	M10	2	053
	60	M5	4	280
	63	Ø7	4	057
50,8	93	M8	2	287
	82,50	M8	2	050
52	/	/	/	/
56	/	/	/	/
	76	M6	4	234
57,15	106,4	Ø11	2	212
60	74	M10	4	098
	98,5	M6	4	147
	75	M6	4	227
62,7	157,2	M12	4	231
63	100	M8	2	042
	125	M6	4	043
	160	M8	4	044
	80	M8	2	051
65	80	Ø8,5	4	058
	100	M10	2	062
	85	M8	4	168
	90	M8	4	271
70	84	Ø7	4	289
71,8	88,9	M10	4	047
75	102	M10	4	139
80	100	M8	4	024
	103,2	M8	2	045
	100	Ø11	4	059
	100	M10	2	061
	110	M10	2	063
	140	M10	2	064
	115	M10	2	065
	100	M10	4	067
	106,4	M10	2	083
	130	M8	4	087
	100	Ø8,5	4	093
82,55	113	M12	4	104
	95	M8	4	169
	103	M8	4	242
	110	M10	4	272
	106,4	M10	2	060
	105	M10	4	097
	106,4	M8	2	254
85	146	M12	2	260
	110	M10	2	284
90	112	M8	2	134
90	105	M8	4	156
	118	Ø9	2	163
	112	Ø9	2	164

Spigot hole mm	BCD	D	N° holes	Code
92	140	M8	4	088
	145	M10	4	089
95	115	M8	4	137
95,2	127	M10	4	131
98,4	125	Ø11	4	128
100	125	M10	2	023
	125	M10	4	025
	125	Ø11	4	031
	125	Ø11	4	032
	190	Ø15	4	038
	125	Ø13	4	041
	125	M12	2	071
	140	M12	2	072
	146	M12	2	075
	126	M10	2	106
	120	M8	4	122
101,6	160	M10	4	141
	150	M10	4	150
	161,5	M12	4	029
	146	M12	2	070
	127	M12	4	125
	146	M10	2	159
	127	M10	4	224
105	146	M12	2	076
110	175	M10	4	110
	130	M8	4	154
	200	M10	4	202
	135	M10	4	219
112	145	M12	4	273
	140	M12	2	074
	140	M10	2	138
115	130	M10	4	264
	180	M12	4	198
116	160	M14	2	084
120	210	M16	2	094
	145	M10	4	155
	150	Ø13	4	267
125	160	M12	4	026
	160	Ø13	4	033
	160	M12	2	079
	180	M16	2	082
	155	M10	4	102
	160	Ø17	4	113
	200	M12	4	114
	181,2	M16	2	136
	200	M16	4	200
	180	Ø20	4	215
	170	Ø18	4	237
127	161,5	M12	4	021
	181,2	M16	2	080
	161,5	M14	4	140
130	165	Ø11	4	054
	150	M12	4	068
	181,2	M16	2	085
	165	M12	4	124
	165	M14	4	135

Spigot hole mm	BCD	D	N° holes	Code
130	165	M10	4	253
135	160	M10	4	151
	175,4	M12	4	220
140	180	M140	4	077
	180	M12	2	281
	165	M10	4	157
	200	M16	4	176
	165	M10	4	223
150	180	M16	2	232
	185	M16	4	069
152,4	228,6	M16	4	022
	228,6	M18	2	090
	228,6	M18	41	108
	217,5	Ø17	4	118
	228,6	M20	2	166
	228,6	M20	4	192
	190,5	M8	4	207
160	200	M16	4	027
	200	Ø17	4	035
	200	M16	2	091
	224	M20	2	092
	200	M12	2	107
	230	M22	4	111
	185	M12	4	152
162	224	M16	4	184
	230	22	4	228
165,1	188	M12	4	263
	317,35	M20	4	143
	317,35	M24	2	145
	229	M20	4	201
	317,35	M18	4	204
175	200	M12	4	153
	230	M18	2	185
	350	M24	4	146
177,8	216	M12	4	222
	350	M24	4	203
	216	13	4	055
	216	M16	4	078
180	224	M16	4	112
	216	M12	4	132
	215	M22	4	148
	230	22	4	226
	250	M20	4	028
200	250	Ø22	4	095
	280	M24	2	117
	230,5	M12	4	214
203,2	254	M14	4	210
205	240	M16	4	133
224	280	M20	4	144
	280	Ø22	4	205
250	310	M24	4	238
	315	M20	4	282
275	355	M16	4	233
	355	Ø18	4	281
-	-	-	-	-
-	-	-	-	-

A guide to select the correct bell-housing and drive coupling components

DATA REQUIRED

Electric motor power/motor size
 Manufacturer and pump type

TO VERIFY:

- 1 - Pump and motor shaft dimensions (see page 69)
- 2 - Shaft and flange pump (see pump data sheet)

Example:

- Electric motor 2 kW - 4 poles - Motor size 110/112
- Atos pump code PFE31 - Shaft 1

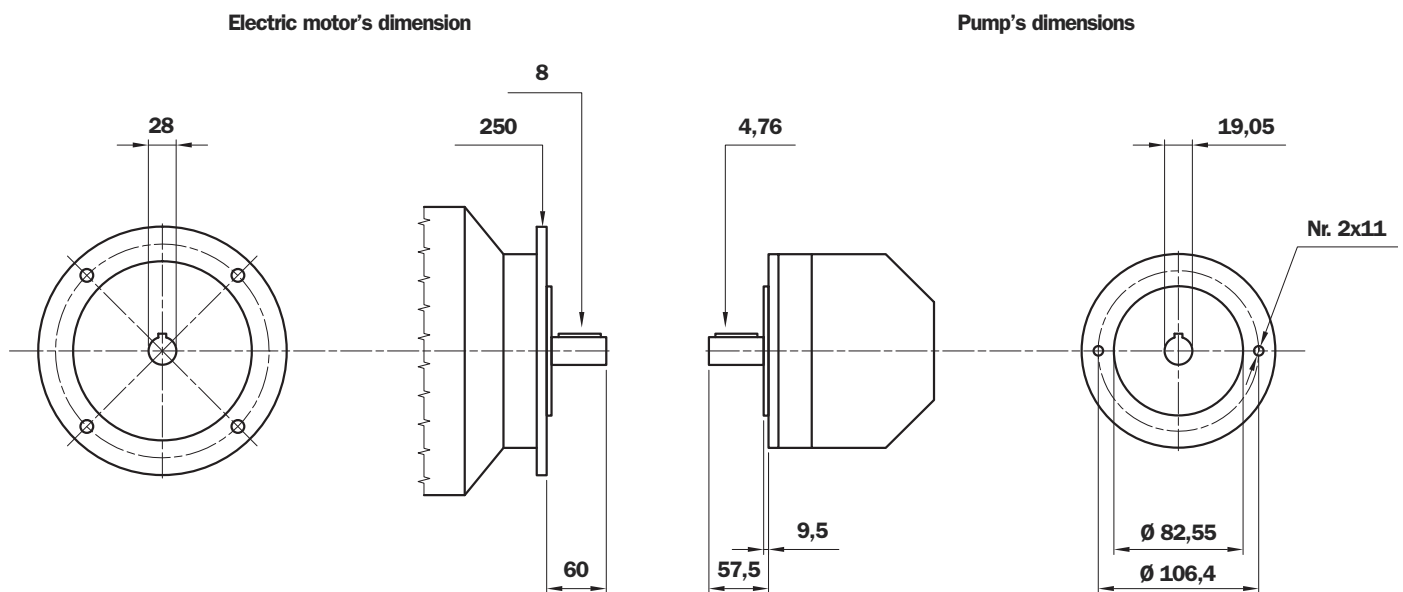

Bell-Housing's length calculation

- $H = 60 + 18 + 57,5 = 135,5$ mm (18= Sp spider - see page 49)
- Choose type of bell-housing (LMC - LMS)
 - For LMC see tab. 3 at page 11
 - For LMS see tab. 21 at page 32
 - For MODUL 2/3 see at page 36

Note: The length of bell-housing must be \geq than the length calculated (135,5 mm)

Case A - solution with LMC bell-housing

Tab. 3 at page 11 - for electric motor 2kW LMC 250
 LMC 250 bell-housing with height $\geq 135,5$ - LMC250AFSQ

- The bell-housing code must be completed with drilling pump code (see tab. 34 at page 47)
 For the specific case C= 101,6 - Nr. 2 holes M10: Code drilling 070
- Definitive bell-housing code **LMC250AFSQ070**

Case B - solution with LMS bell-housing

Tab. 21 at page 32 - for electric motor 2kW LMS 250
 LMS 250 bell-housing with height $\geq 135,5$ - LMS250AFSQ

- The bell-housing code must be completed with drilling pump code (see tab. 34 at page 47)
 For the specific case C= 101,6 - Nr. 2 holes M10: Code for. 070
- Definitive bell-housing code **LMS250AFSQ070**

Choose coupling

- **Motor half-coupling** (see tab. 37 at page 50)
 - For electric motor GR 100/112, the half-coupling is **SGEA21M05060**
- **Spider** (see tab. 35 - 36 at page 49)
 - For SGEA21, EGE2 - EGE2RR
(choose spider material on the base of the application, oil, temperature and cycle machine, etc.)
- **Pump half-coupling**
 - Choose the drilling code tab. 43 - 44 at page 53 for shaft 19,05 - Ch. 4,76 - code: **G01**
 - Half-coupling length = L BH length - THK Spider - THK Spigot
 $138 \text{ mm} - 60 - 18 - 9,5 = 50,5 \text{ mm}$
 - Choose the half-coupling's length on tab. 38 at page 50 $\leq 50,5 \text{ mm}$.
 - Availabe length for SGEA21= 50 mm
 - Code half-coupling code: **SGEA21G01050**

**Software for automatic calculation available on the web site
www.mpfiltri.com - tools - software**

The screenshot shows the MP Filtri software interface for pump and motor selection. The interface is divided into several sections:

- HYDRAULIC PUMP - Technical Data:**
 - AKA: AKM0320068
 - Manufacturer: ATOS
 - Pump type: PFE
 - Pump model: PFE31 Shaft 1
 - Technical Data: L1: 57.5, d1: 19.05, Ch1: 4.76, E: 9.5, Pd: 82.55, Bd: 106, Wc: 2, F: M20
- ELECTRIC MOTOR - Technical Data:**
 - N. Pole: 2P
 - Type: M3-B5
 - Size: 100-112
 - Sec: 3-4
 - tp: 4-5,44
 - Technical Data: L1: 60, H1: 28, Fig: 256, Ch: 8
- Coupling material:**
 - Aluminium
 - Cast iron
 - Other alternative material
- Result:**
 - Coupling: M01 - 21066
 - Drilling Pump: 5000
 - Pump Shaft: G01
 - Motor Shaft: M01
 - Monobloc Bellhousing:
 - Modular Bellhousing:
 - Silenced Bellhousing:

A red button labeled "CLICK HERE TO PROCEED" is located at the bottom left of the interface.

Note: For multi pumps we recommend to use a specific support on the base of the pump's dimensions and weight.

Half-coupling SGE*** series

The half-couplings series SGE*** allow secure transmission between the electric motor and the driven side; they are able to absorb shocks and vibration, in addition to compensating radial misalignment, angular and axial.

The assembly of the couplings can be horizontal/vertical, withstanding vibration and load reversals.

The complete range of couplings are extrapolated from the on-line software, with a length equal than the shaft on which must be mounted and they are completed with grub screw for fixing located on the key.

Available for cylindrical shaft with metric and imperial dimensions as well for splined shafts as per specification DIN, ISO and SAE.

Admissible misalignment radial, angular and axial

Max admissible radial misalignment

Half coupling	R (mm)
SGE * 01	0,5
SGE * 21	1,0
SGE * 31	1,0
SGE * 40	1,0
SGE * 51	1,5
SGE * 60	1,5
SGE * 80	2,0
SGE * 90	2,0

Max admissible angular misalignment

Half coupling	β (°)
SGE * 01	
SGE * 21	
SGE * 31	
SGE * 40	1,5°
SGE * 51	
SGE * 60	
SGE * 80	
SGE * 90	

Max admissible angular misalignment

Half coupling	A (mm)
SGE * 01	2,0
SGE * 21	2,5
SGE * 31	3,0
SGE * 40	3,5
SGE * 51	3,5
SGE * 60	3,5
SGE * 80	4,0
SGE * 90	5,0

Normative ATEX 94/9/CE

Half-couplings SGE*** series are available to use in hazardous area.

The couplings are certified according to ATEX 94/9/CE (ATEX 95).

Category certified 2G - area 1 and 2.

Other information available on our web site "www.mpfiltri.com".

MP Filtri couplings are developed with:

CAD 3D



FEM (calculation)



Drawings 3D available on website www.mpfiltri.com at section TOOLS/2D-3D COMPONENTS

The half-couplings SGE*** series are in conformity to normative **DIN 740/2**.
The max torque to transmit is always less than the max torque that the coupling can transmit.

Examples verification of the coupling

Torque transmitted by electric motor:

Mt: $9560 \times \text{kW} / \text{rpm} = \text{Nm}$

Me > $\text{Mt} \times \text{S} = \text{Nm}$

Where:

Mt: Torque transmitted by electric motor

Me: Torque transmitted by coupling (see table 14)

kW: Power of electric motor

Rpm: Revolutions per minute of electric motor

S: Service factor (see table 14)

TABLE 1

Small pumps, uniform load, low operating pressures e.g. rotary action machine tools - 5/8 work cycles per hour	1.3
Small pumps, uniform load, high working pressures e.g. lifting equipment - 120-150 work cycles per hour	1.5
Pumps, non-uniform load e.g. lifting equipment - 280-300 work cycles per hour	1.7

Example

Electric motor, 4 pole - 4 kW

hydraulic pump, uniform load, low operating pressure

Mt: $9560 \times 4 / 1500 = 25.45 \text{ Nm}$

Me > $25.49 \times 1.3 = 33 \text{ Nm}$

Half-coupling SGEA21 meets the above requirement.

Select the half-coupling of the calculated size from the motor half-couplings table.

Note: When selecting the coupling, remember that for pumps with splined shaft, only cast iron couplings of the SGEG series can be used.

Determine the size of the coupling according to the type of installation and application envisaged, on the basis of the following formulas and tables:

TABLE 2

Half-coupling type	External diameter mm	Nominal torque Me - Nm	Maximum transmissible torque Me - Nm	
ALUMINIUM	SGEA01	43	15	20
	SGEA21	68	160	190
	SGEA31	85	340	380
	SGEA51	109,5	550	620
CAST IRON	SGEG01	40	20	30
	SGEG30	80	400	450
	SGEG40	95	550	620
	SGEG60	120	760	850
	SGEG80	160	2200	2500
	SGEG90	200	5500	6100
STEEL	SGES40	95	550	620
	SGES60	120	760	850
	SGES80	160	2200	2500

Nominal and maximum torque values are referred to couplings assembled with standard flexible spiders of the **EGE**** series (see page 49).

Where higher torques are to be transmitted, use flexible spiders of the **EGE**RR** series (see page 49).

Noise

Noise is a particularly pervasive problem so much so that there have been statutory regulations in place now for some years, designed to limit harmful occupational exposure. Many of the machines used in industry today are equipped with oil-hydraulic systems, which happen to be a major source of noise.

1. Theory and definition of noise

From a health and hygiene standpoint, noise can be defined as an unpleasant and undesirable sound, or an unpleasant and annoying or intolerable auditory sensation (noise being any sound phenomena that may be accompanied by sensations of disturbance and pain). By definition, acoustic phenomena are oscillatory in character, propagated in a flexible medium and causing pressure variations at the points, and the areas adjacent to those points, through which they pass.

2. Sound

Technically considered, certain elements must be present simultaneously for acoustic phenomena to occur:

- Sound source
- Transmission medium
- Receiver

Motor and pump unit

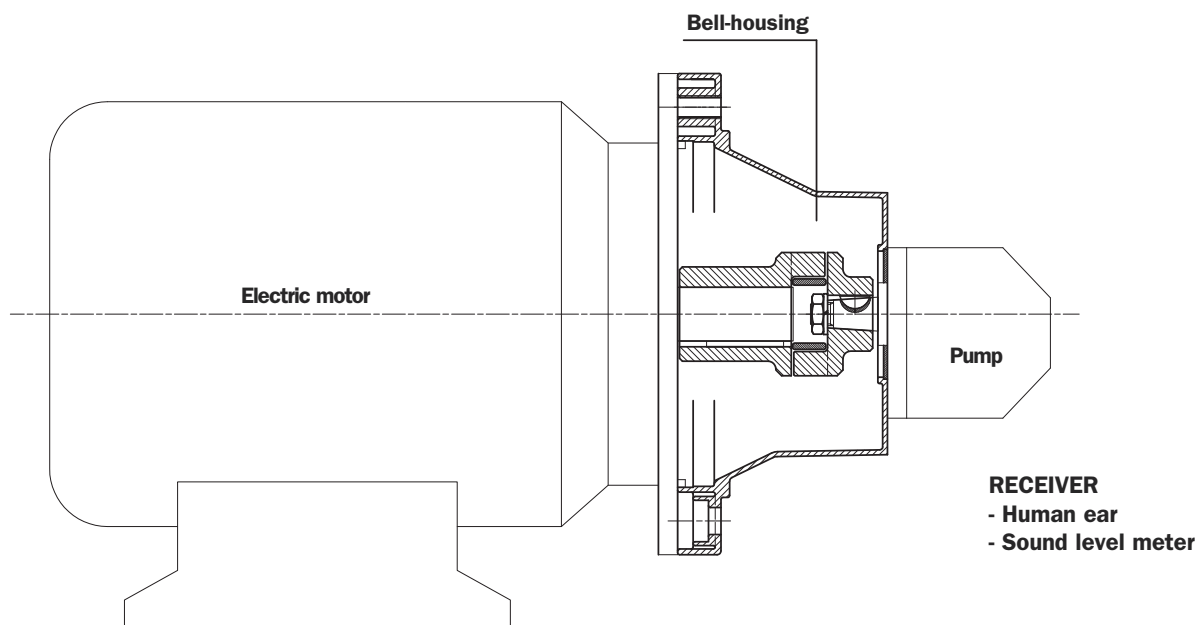

The **electric motor** and the **pump**, together with the drive coupling, are the **SOURCE OF THE NOISE**.

The **Bell-housing** is the noise transmission medium.

Depending on whether the monobloc bell-housing is a rigid or low noise type, there will be variations in the flexible properties of the transmission medium.

The acoustic phenomena are dissimilar in the two cases, given the differences in pressure variation and particle displacement.

Assembly of motor and pump unit

As mentioned in the presentation, low noise bell-housing will help to attenuate the transmission of vibrations and the emission of noise generated by the system.

Self-evidently, however, the mere adoption of a low noise bell-housing will achieve little unless the motor and pump are correctly installed on the machine, or on the tank of the hydraulic power unit.

- Should be followed in order to achieve best possible results and correct installation:

1. Motor and pump unit mounted horizontally on oil tank lid

- The suction pipe attached to the pump must be rigid, and fitted using a resilient bulkhead flange of the FTA series, which helps to cushion the vibrations propagated between the pipe and the tank lid. If pipes need to be bent, the radius of curvature must be at least 3 times the pipe diameter. Do not use elbow fittings, as these will significantly increase pressure losses.
- The pressure pipeline of the pump must be flexible, and long enough to include bends with the minimum radius of curvature recommended by the manufacturer for the specified operating pressure.
- The return pipeline running from the service to the filter must be flexible. Where oil is returned directly to the tank of the hydraulic power unit through a rigid pipe, it is advisable to use a resilient bulkhead flange of the FTR series, which helps to cushion the vibrations propagated between the pipe and the tank lid.
- Anti-vibration devices (resilient mounts or damping rods) must be located under the feet of the electric motor or the PDM foot brackets, depending on the mounting position of the motor.
- The lids of hydraulic oil tanks must be sturdy enough to support the load they carry.

2. Motor and pump unit mounted horizontally on machine

- As a matter of good practice, the oil tank and motor-pump unit should be mounted on a single supporting frame of strength sufficient to support the load.
- If the hydraulic system is fitted with a side-mounted filter, the suction pipeline to the pump must be flexible, and long enough to include bends with the minimum radius of curvature recommended by the manufacturer.
- If the suction filter is not side mounted, the pipeline should be rigid and installed in conjunction with a compensating coupling.
- The pressure pipeline of the pump must be flexible, and long enough to include bends with the minimum radius of curvature recommended by the manufacturer for the specified operating pressure.
- The return pipeline running from the service to the filter must be flexible. Where oil is returned directly to the tank of the hydraulic power unit through a rigid pipe, it is advisable to use a resilient bulkhead flange of the FTR series, which helps to cushion the vibrations propagated between the pipe and the tank lid.
- Anti-vibration devices (resilient mounts or damping rods) must be located under the feet of the electric motor or the PDM foot brackets, depending on the mounting position of the motor.

Note: The above guidelines are indicative only, and subordinate to the solutions adopted ultimately by design engineers.

In conclusion: For best results, in any event, the motor-and-pump unit should be incorporated into the hydraulic system in such a way that no one component is rigidly associated with another, resulting in the propagation of vibration, and consequently noise.

Table of summary MODUL 2/3

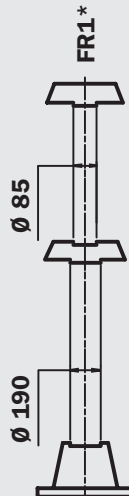
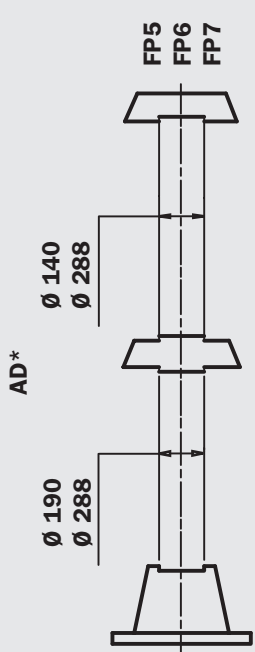
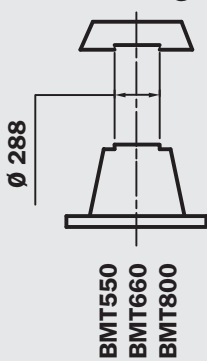
	5.5 - 7.5 kW	11 - 22	30	37 - 45	55 - 90	110 - 200	250 - 400
	7.5 - 10.2 Hp	15 - 30 Hp	40.80 Hp	50.32 - 61.2 Hp	75 - 125 Hp	150 - 272 Hp	340 - 544 Hp
	Size 225 - D.450	Size 160/180 D.350	Size 200 - D.350	Size 225 - D.450	Size 250/280 D.550	Size 315 - D.660	Size 355/400 D.800
MODUL 2	<p>AR*</p>  <p>BMT300 BMT350</p> <p>Kit of assembly KVG5 (Q.ty 1) + Kit of assembly KVG1 (Q.ty 1)</p>						
	<p>AD*</p>  <p>BMT350 BMT400 BMT450</p> <p>Kit of assembly KVG5/7 (Q.ty 2)</p>						
MODUL 3	 <p>BMT550 BMT660 BMT800</p> <p>Kit of assembly KVG6/7 (Q.ty 1)</p>						
	5.5 - 7.5 kW	11 - 22	30	37 - 45	55 - 90	110 - 200	250 - 400
7.5 - 10.2 Hp	15 - 30 Hp	40.80 Hp	50.32 - 61.2 Hp	75 - 125 Hp	150 - 272 Hp	340 - 544 Hp	
Size 225 - D.450	Size 160/180 D.350	Size 200 - D.350	Size 225 - D.450	Size 250/280 D.550	Size 315 - D.660	Size 355/400 D.800	

Drive couplings

SGEA-SGEG-SGES series

Drive couplings provide the means by which power is transmitted from the electric motor to the hydraulic pump.

By virtue of their flexible structure, they are able to compensate angular and radial misalignments between motor and pump, and appreciably attenuate the noise generated through the drive line.

The couplings illustrated are available in aluminium and cast iron versions, with a variety of spider options, and will cover a range of applications using electric motors from **size 63**, rated **0.15 kW**, up to **size 400** rated **400 kW**.

Grub screw on all half couplings.

Cast iron half coupling SGEG available with screw mounted.

Technical specifications

SGEA - SGEG - SGES

Materials

- **Motor half-coupling**
Pressure diecast aluminium/cast iron/steel.
- **Pump half-coupling**
Pressure diecast aluminium/cast iron/steel.
- **Spiders**
Oil-resistant rubber, black, Shore A hardness 87
Polyurethane resin, red, Shore A hardness 98

Temperature

- **Oil-resistant rubber:**
-20°C ÷ +90°C
- **Polyurethane resin:**
-40°C ÷ +120°C

For temperatures outside this range, contact the MP Filtri Technical and Sales Department.



Compatibility with fluids

- **Modular bell-housing components compatible for use with:**

Mineral oils

Types HH-LL-HM-HR-HV-HC, to ISO 6743/4 standard

Water based emulsions

Types HFAE - HFAS, to ISO 6743/4 standard

Water glycol

Type HFC, to ISO 6743/4 standard

Ask for anodized version

Special Applications

- **Any applications not covered by the normal indications contained in this catalogue must be evaluated and approved by the MP Filtri Technical and Sales Department.**

EGE** series

Made of black oil-resistant rubber, these components serve to interconnect the two halves (motor - pump) of a flexible coupling. They are suitable for all industrial applications and will withstand temperatures from -20°C to +90°C.
Shore A hardness 87

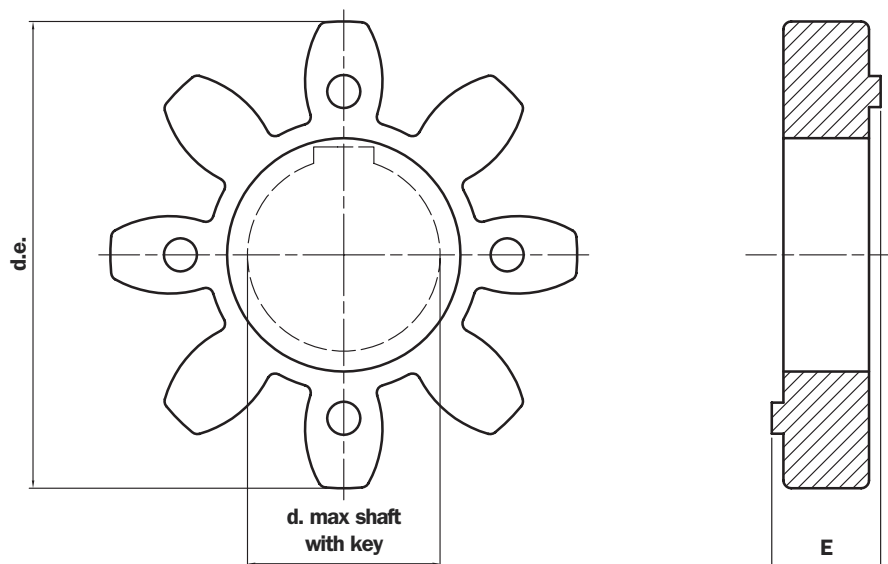

TABLE 35

Half-coupling type	Code	E	d.e.	d.max	Nominal torque Nm	Max torque Nm	Weight (kg)
SGEA01/SGEG01	EGE0	15	40	16	10	20	0,006
SGEA21	EGE2	18	65	25	95	190	0,02
SGEA31/SGEG31	EGE3	22	80	35	190	380	0,04
SGEA51	EGE5	26	105	45	310	620	0,06
SGEG40/SGES40	EGE4	24	95	40	310	620	0,09
SGEG60/SGES60	EGE6	28	120	55	430	860	0,13
SGEG80/SGES80	EGE8	38	160	75	1250	2500	0,36

EGE**RR series

Made in polyurethane Laripur - E 2203-93A, red colour, are suitable for applications where high levels of torque are transmitted. They will withstand temperatures from -30°C to +120°C.
Shore A hardness 95

TABLE 36

Half-coupling type	Code	E	d.e.	d.max	Nominal torque Nm	Max torque Nm	Weight (kg)
SGEA01/SGEG01	EGE0RR	15	40	16	15	30	0,006
SGEA21	EGE2RR	18	65	25	115	230	0,02
SGEA31/SGEG31	EGE3RR	22	80	35	250	500	0,04
SGEA51	EGE5RR	26	105	45	400	800	0,06
SGEG40/SGES40	EGE4RR	24	95	40	380	760	0,09
SGEG60/SGES60	EGE6RR	28	120	55	550	1100	0,13
SGEG80/SGES80	EGE8RR	38	160	75	1400	2900	0,36
SGEG90	EGE9RR	42	200	95	8900	9900	0,59

Version for extreme temperatures available on request.

For further information, contact the MP Filtri Technical and Sales Department.

SGEA motor half-coupling aluminum

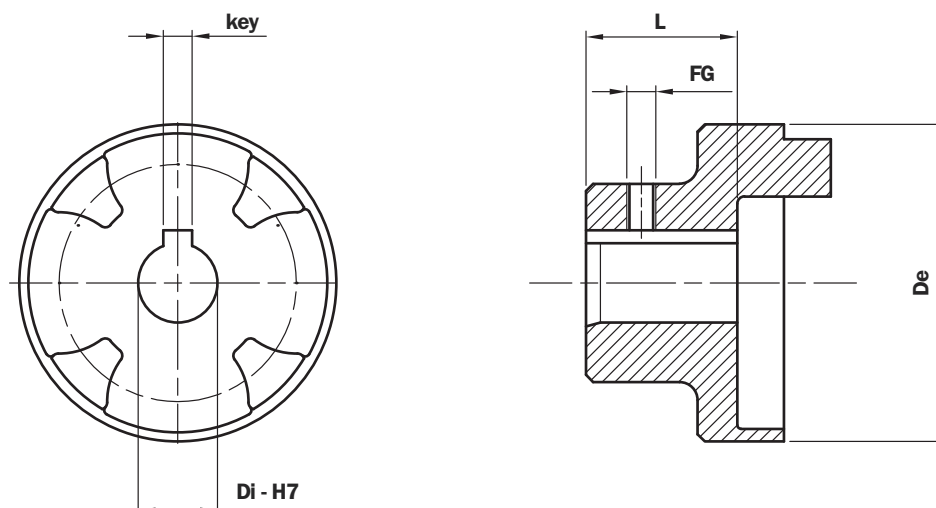

TABLE 37 - Motor half-coupling

Motor 4-pole 1500 rpm				Dimensions of motor half-coupling								
Frame size	kW	Hp	Shaft	Half-coupling code	D	L	d	Tol	key	Tol	FG	Weight (kg)
63	0.12 - 0.16	0.18 - 0.24	11x23	SGEA01M01021	43	21	11		4		M5	0,07
71	0.25 - 0.34	0.37 - 0.50	14x30	SGEA01M02028	43	28	14		5		M5	0,08
80	0.53 - 0.75	0.75 - 1	19x40	SGEA01M03040	43	44	19		6		M5	0,12
				SGEA21M03040	68	44	19		6		M6	0,30
90	1.1 - 1.5	1.5-2	24x50	SGEA01M04048	43	48	24		8		M5	0,13
				SGEA21M04048	68	48	24		8		M6	0,28
100 - 112	2.2-4	3.5.5	28x60	SGEA21M05060	68	60	28		8		M6	0,33
				SGEA31M05060	85	60	28	H7	8	D10	M8	0,48
132	5.5-7.5	7.5-12.5	38x80	SGEA31M06077	85	77	38		10		M8	0,78
				SGEA51M06077	109,5	77	38		10		M8	1,60
160	11-15	15-20	42x110	SGEA51M07109	109,5	110	42		12		M8	1,60
180	18-22	25-30	48x110	SGEA51M08109	109,5	109	48		14		M8	1,60
200	30	40	55x110	SGEA51M09109	109,5	109	60		16		M8	1,90
225	37-45	50-61	60x140	SGEA51M10109	109,5	109	109		18		M8	1,90

TABLE 38 - Pump drive half-couplings

Half-coupling code	d min	d max	D	Tol	L min	L max	Standard lengths										FG	
SGEA01 *** **	11	19	43	H7	17	50	17	23	30	40	44	48	-	-	-	-	-	M5
SGEA21 *** **	15	24	43	H7	23	50	35	40	42	44	48	50	-	-	-	-	-	M6
SGEA21 *** **	25	28	70	H7	40	60	40	42	44	48	50	55	58	60	-	-	-	M6
SGEA31 *** **	18	32	70	H7	40	60	42	45	48	50	52	55	58	60	-	-	-	M8
SGEA31 *** **	38	42	85	H7	60	80	60	65	70	77	80	-	-	-	-	-	-	M8
SGEA51 *** **	18	40	109,5	H7	40	70	42	45	48	50	52	55	58	60	65	70	-	M8
SGEA51 *** **	38	55	109,5	H7	70	109	70	75	80	85	90	95	100	105	109	-	-	M8

Complete the half-coupling designation with the pump interface code and the length.

Ex. **SGEA51D02040** **D02** See **Table 43** **040** Half-coupling length (see **Table 38**).

Note: Screw not included

.....

.....

.....

.....

SGEG half-coupling cast iron

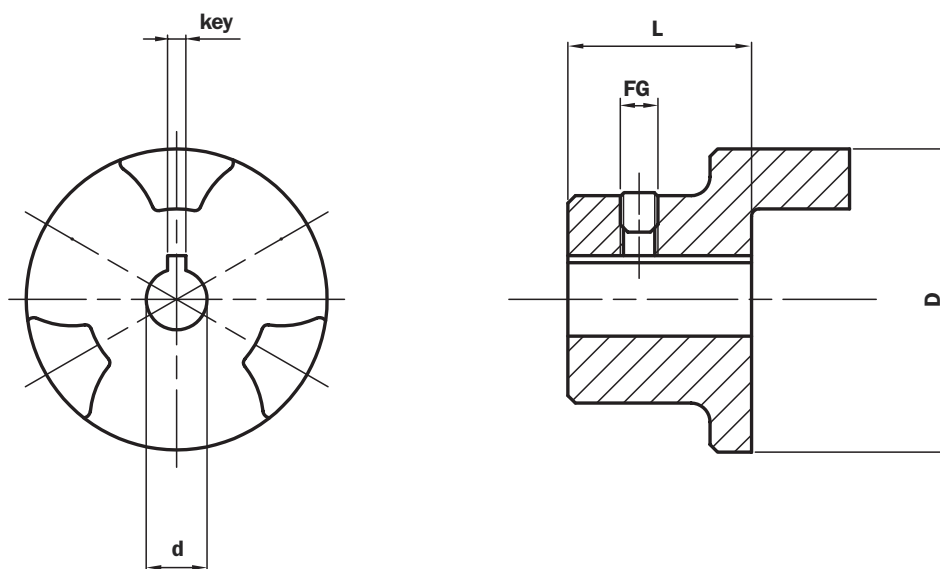

TABLE 39 - Motor half-coupling

Motor 4-pole 1500 rpm				Dimensions of motor half-coupling									
Frame size	kW	Hp	Shaft	Half-coupling code	D	L	d	Tol	key	Tol	FG	Weight (kg)	
63	0.12 - 0.16	0.18 - 0.24	11x23	SGEG01M01021	43	21	11		4		M6	0,32	
71	0.25 - 0.34	0.37 - 0.50	14x30	SGEG01M02028	43	28	14		5		M6	0,42	
80	0.53 - 0.75	0.75 - 1	19x40	SGEG01M03040	43	40	19		6		M6	0,61	
90	1.1 - 1.5	1.5-2	24x50	SGEG01M04050	43	50	24		8		M6	0,77	
100 - 112	2.2-4	3-5.5	28x60	SGEG31M05060	80	60	28	H7	8		M6	2,35	
				SGEG40M05060	95	60	28		8		M8	2,65	
132	5.5-7.5	7.5-12.5	38x80	SGEG31M06080	80	80	38		10		M6	3,15	
				SGEG40M06080	95	80	38		10		M8	3,55	
160	11-15	15-20	42x110	SGEG40M07110	95	110	42		12		M8	4,70	
180	18-22	25-30	48x110	SGEG40M08110	95	110	48		14		M8	4,55	
200	30	40	55x110	SGEG40M09110	95	110	55		16	JS9	M8	4,35	
				SGEG60M09110	120	110	55		16		M8	9,00	
225	37-45	50-60	60x140	SGEG60M10140	120	140	60		18		M8	12,30	
250	55	75	65x140	SGEG60M11140	120	140	65		18		M8	12,00	
				SGEG80M11140	160	140	65		18		M8	18,30	
				SGEG60M12140	120	140	75		20		M10	11,50	
280	75-90	102-122	75x140	SGEG80M12140	160	140	75	F6	20		M10	17,70	
				SGEG90M12100	200	100	75			20		M10	21,00
				SGEG80M13170	160	170	80			22		M10	20,60
315	110-200	150-272	80x170	SGEG90M13100	200	100	80		22		M10	20,00	
				SGEG90M15100	200	100	95		25		M10	19,00	
355	250-315	340-428	95x140	SGEG90M15100	200	100	95		25		M10	19,00	
400	355-400	482-544	100x210	SGEG90M16100	200	100	100		80		M10	18,00	

TABLE 40 - Pump drive half-couplings

Half-coupling code	d min	d max	Tol	D	L min	L max	Standard lengths every 5 mm
SGEG01 *** **	/	24	H7	40	20	50	
SGEG30 *** **	/	42	H7	80	30	80	
SGEG40 *** **	/	55	H7	95	30	110	
SGEG60 *** **	/	75	H7	120	40	140	
SGEG80 *** **	/	85	H7	160	50	170	
SGEG90 *** **	/	100	H7	200	40	100	

All SGEG series cast iron half-couplings are supplied with a grub screw hole as standard, and with a grub screw UNI 5929 DIN 916 fitted to the hub.

Note: For lengths other than those indicated in table 40, contact the MP Filtri Technical and Sales Department.

SGES*G0 series pump drive half-couplings

SGES series half-couplings, made of hardened and tempered C40 steel, are designed to eliminate any clearance between the hub and the shaft on which they are mounted.

All SGES couplings are balanced and supplied complete with property class 12.9 fixing screws.

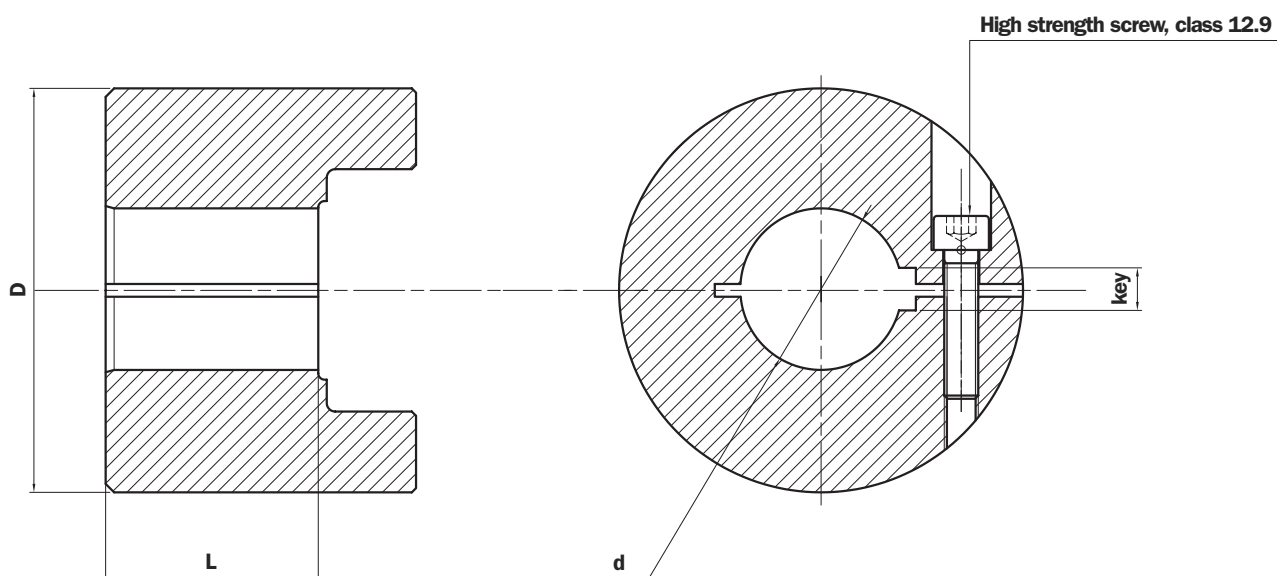

SGES series motor half-couplings - steel

TABLE 41

Motor 4-pole 1500 rpm				Dimensions of motor half-coupling								
Frame size	kW	HP	Shaft	Half-coupling code	D	L	d	Tol	key	Tol	Screw	Weight (kg)
132	5.5-7.5	7.5-12.5	38x80	SGES40M06050G0	95	50	38		10		M8	4,00
160	11-15	15-20	42x110	SGES40M07065G0	95	65	42		12		M8	5,00
180	18-22	25-30	48x110	SGES40M08065G0	95	65	48		14		M8	5,00
200	30	40	55x110	SGES60M09085G0	120	85	55	H7	16	JS9	M10	8,00
225	37-45	50-61	60x140	SGES60M10085G0	120	85	60		18		M10	8,00
250	55	75	65x140	SGES60M11085G0	120	85	65		18		M10	8,00
280	75-90	102-122	75x140	SGES60M12085G0	120	85	75		20		M10	8,00
315	110-200	150-272	80x170	SGES80M13085G0	160	170	80		22		M10	13,00

SGES series pump half-couplings - steel

TABLE 42

Half-coupling code	d min	d max	Tol	D	L
SGES40 *** **	/	55	H7	95	35
SGES60 *** **	/	65	H7	120	65
SGES80 *** **	/	75	H7	160	85

Complete the half-coupling designation with the pump interface code and the length.

Ex. **SGES40PD02050 PD02** See **Table 43 - 44**

.....

.....

.....

.....

.....

Half-coupling bore size codes

TABLE 43

Bore size code - cylindrical shafts (SGEA - SGEG - SGES series)																	
Diameter	key	Code	Diameter	key	Code	Diameter	key	Code	Diameter	key	Code	Diameter	key	Code	Diameter	key	Code
12	4	C00	35	10	D05	14	5	M02	19,05	4,76	G01	13,45	3,18	H07			
15	5	C01	40	12	D06	19	6	M03	22,22	4,76	G02	17,46	4,76	H08			
16	4	C02	45	14	D07	24	8	M04	22,22	6,35	G03	12,7	3,18	H09			
16	5	C03	50	14	D08	28	8	M05	25,4	6,35	G04	15,87	3,97	L00			
17	5	C04	70	20	D09	38	10	M06	25,4	4,76	G05	22,22	4	L01			
18	6	C05	22	8	D10	42	12	M07	31,75	6,35	G06	28,58	6,35	L02			
20	5	C06	8	3	E00	48	14	M08	31,75	7,94	G07	19,05	6,35	L03			
19	5	C07	10	3	E01	55	16	M09	34,94	7,94	G08	47,63	12,7	L04			
30	10	C08	22	5	E02	60	18	M10	38,1	9,52	G09	85,73	22,23	L05			
20	6	C09	32	8	E03	65	18	M11	41,27	9,52	H00	60,33	15,88	L06			
16	5	C10	35	8	E04	75	20	M12	44,45	11,11	H01	60,33	12,7	L07			
22	6	D00	82	22	E05	80	22	M13	50,8	12,7	H02	73,03	19,05	L08			
24	6	D01	25	7	E06	90	25	M14	53,94	12,7	H03	92,07	22,22	L09			
25	8	D02	63	18	E07	95	25	M15	19,02	3,17	H04	41,6	12	L10			
30	8	D03	9	3	M00	100	28	M16	25,4	4,76	H05						
32	10	D04	11	4	M01	11,11	3,18	G00	15,87	4,76	H06						

Combinations with double key:

G02+G03 **2E** G06+G07 **2G** C07+M03 **2L** D01+M04 **2N**

G04+G05 **2F** C02+C03 **2H** C06+C09 **2M** D03+C08 **2P**

Ex. Code SGEA21G02050**2E**

TABLE 44

Bore size code - splined shafts (SGEG - SGES half-couplings only)											
Profile	Standard	Code	Profile	Standard	Code	Profile	Standard	Code	Profile	Standard	Code
17th 8/16	Diametral Pitch	PD01	30th 32/64	Diametral Pitch	PD24	W55x2x26	DIN 5480	PA16	A55x50	DIN 5482	PB18
14th 12/24	Diametral Pitch	PD02	33th 32/64	Diametral Pitch	PD25	W60x2x28	DIN 5480	PA17	A58x53	DIN 5482	PB19
16th 12/24	Diametral Pitch	PD03	23th 40/80	Diametral Pitch	PD26	W70x2x34	DIN 5480	PA18	A60x55	DIN 5482	PB20
17th 12/24	Diametral Pitch	PD04	36th 48/96	Diametral Pitch	PD27	W80x2x38	DIN 5480	PA19	A62x57	DIN 5482	PB21
9th 16/32	Diametral Pitch	PD05	41th 48/96	Diametral Pitch	PD28	W60x3x18	DIN 5480	PA20	A65x60	DIN 5482	PB22
11th 16/32	Diametral Pitch	PD06	47th 48/96	Diametral Pitch	PD29	W70x3x22	DIN 5480	PA21	A68x62	DIN 5482	PB23
12th 16/32	Diametral Pitch	PD07	13th 8/16	Diametral Pitch	PD30	A15x12	DIN 5482	PB01	A70x64	DIN 5482	PB24
13th 16/32	Diametral Pitch	PD08	15th 8/16	Diametral Pitch	PD31	A17x14	DIN 5482	PB02	A72x66	DIN 5482	PB25
15th 16/32	Diametral Pitch	PD09	W18x1,25x13	DIN 5480	PA01	A18x15	DIN 5482	PB03	A75x69	DIN 5482	PB26
21th 16/32	Diametral Pitch	PD10	W20x1,25x14	DIN 5480	PA02	A20x17	DIN 5482	PB04	A78x72	DIN 5482	PB27
23th 16/32	Diametral Pitch	PD11	W25x1,25x18	DIN 5480	PA03	A22x19	DIN 5482	PB05	A80x74	DIN 5482	PB28
27th 16/32	Diametral Pitch	PD12	W28x1,25x21	DIN 5480	PA04	A25x22	DIN 5482	PB06	A82x76	DIN 5482	PB29
40th 16/32	Diametral Pitch	PD13	W32x1,25x24	DIN 5480	PA05	A28x25	DIN 5482	PB07	A85x79	DIN 5482	PB30
20th 24/48	Diametral Pitch	PD14	W38x1,25x29	DIN 5480	PA06	A30x27	DIN 5482	PB08	A88x82	DIN 5482	PB31
21th 24/48	Diametral Pitch	PD15	W30x2x14	DIN 5480	PA07	A32x28	DIN 5482	PB09	8x10	DIN 5481	PC01
23th 24/48	Diametral Pitch	PD16	W32x2x14	DIN 5480	PA08	A35x31	DIN 5482	PB10	10x12	DIN 5481	PC02
25th 24/48	Diametral Pitch	PD17	W35x2x16	DIN 5480	PA09	A38x34	DIN 5482	PB11	12x14	DIN 5481	PC03
26th 24/48	Diametral Pitch	PD18	W37x2x17	DIN 5480	PA10	A40x36	DIN 5482	PB12	15x17	DIN 5481	PC04
27th 12/48	Diametral Pitch	PD19	W38x2x18	DIN 5480	PA11	A42x38	DIN 5482	PB13	17x20	DIN 5481	PC05
28th 24/48	Diametral Pitch	PD20	W40x2x18	DIN 5480	PA12	A45x41	DIN 5482	PB14	21x24	DIN 5481	PC06
29th 24/48	Diametral Pitch	PD21	W42x2x18	DIN 5480	PA13	A48x44	DIN 5482	PB15	26x30	DIN 5481	PC07
32th 24/48	Diametral Pitch	PD22	W45x2x21	DIN 5480	PA14	A50x45	DIN 5482	PB16	30x34	DIN 5481	PC08
21th 32/64	Diametral Pitch	PD23	W50x2x24	DIN 5480	PA15	A52x47	DIN 5482	PB17	60x65	DIN 5481	PC09

For splined profiles other than those indicated in the table, contact the MP Filtri S.p.A. Technical and Sales Department.

ACCESSORIES

The range of products is completed by a number of accessories, including:

Foot brackets, which serve to support the motor-and-pump unit in the event that the selected electric motor does not have mounting feet.

Damping rings, intended mainly for use with motor-pump units positioned vertically and with the pump submerged in the oil tank.

Inspection covers, facilitating the maintenance of oil tanks in hydraulic power units, without necessarily having to dismantle the unit.

Aluminium tanks of 10 litres capacity, allowing the assembly of a compact hydraulic power unit.

Technical specifications

ACCESSORIES

Materials

- **Foot bracket**
Pressure diecast aluminium alloy.
- **Damping ring**
Vulcanized aluminium.
- **Inspection covers**
Pressure diecast aluminium alloy.
- **Tanks**
Pressure diecast aluminium alloy.

Temperature

- $-30^{\circ}\text{C} \div +80^{\circ}\text{C}$
For temperatures outside this range,
contact the MP Filtri Technical and Sales Department.



Compatibility with fluids

- **Modular bell-housing components compatible for use with:**

Mineral oils

Types HH-HL-HM-HR-HV-HG, to ISO 6743/4 standard

Water based emulsions

Types HFAE - HFAS, to ISO 6743/4 standard

Water glycol

Type HFC, to ISO 6743/4 standard

Ask for anodized version

Special Applications

- **Any applications not covered by the normal indications contained in this catalogue must be evaluated and approved by the MP Filtri Technical and Sales Department.**

Foot brackets

Made of pressure die-cast aluminium and featuring superior mechanical strength, these brackets are proportioned to support **UNEL - MEC** frame electric motors with **B5** mounting flange and no feet.

There are brackets available for a range of motors from **size 71, rated 0.37 kW**, up to **size 180 rated 22 kW**.

(For sizes other than those indicated in the table, contact the MP Filtri Technical and Sales Department).

As already indicated under the heading “**ASSEMBLY OF MOTOR AND PUMP UNIT**”, foot brackets of the **PDM** series should be fitted preferably in conjunction with anti-vibration mounts.

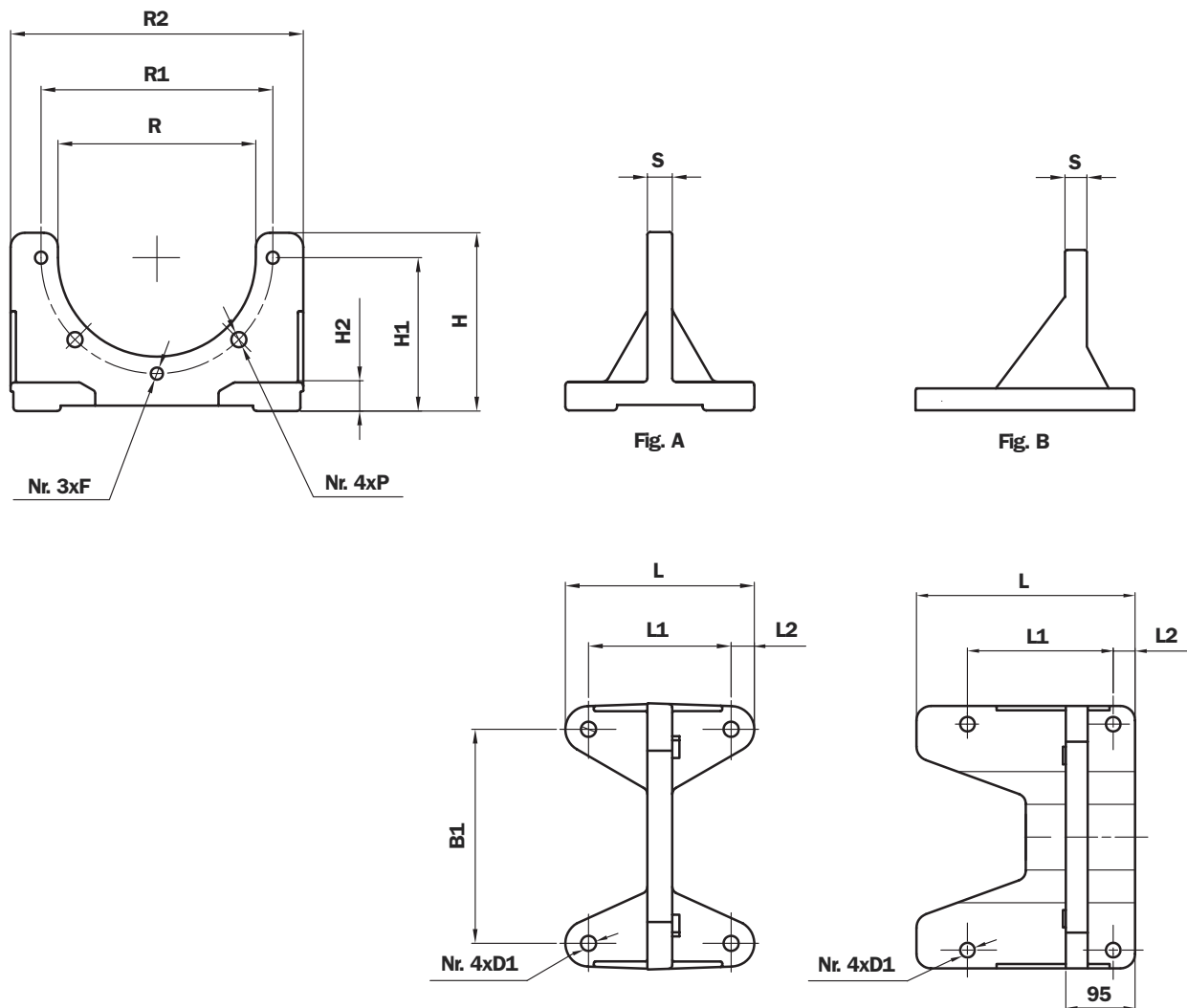

TABLE 45

Foot bracket	Fig.	B	B1	R2	L	L1	L2	H	H1	H2	R	R1	S	P	D1	F	Weight (kg)
PDM A 160	A	160	135	180	106	80	13	100	86	16	111	130	14	8,5	8,5	M8	0,45
PDM A 200	A	200	175	207	128	98	21	128	115	14	146	165	14	11	11,5	M10	0,60
PDM A 250	A	250	220	262	172	130	21	157	145	18	191	215	16	13	13,5	M12	1,20
PDM A 300	A	300	270	320	210	160	25	188	170	18	235	265	20	13	13,5	M12	1,80
PDM A 350	B	350	310	360	300	200	30	220	200	30	261	300	30	18	13	M16	4,80

Damping rings

These vulcanized components consist of two aluminium rings embedded in oil-resistant rubber, which guarantee superior mechanical strength and are particularly suitable for vertically mounted motor-and-pump units.

Positioned between the bell-housing motor flange and the lid of the tank lid, they help to reduce the transmission of vibrations and the emission of noise generated by the system.

Damping rings provide a perfect hydraulic sealing actions by virtue of their special profile, which resembles an O-ring surrounded by a flange with fixing holes.

Rings are available for a range of motors from **size 80, rated 0.5 kW**, up to **size 180 rated 22 kW**.

The noise level of the motor-pump unit can be reduced by as much as 5 dB (8A).

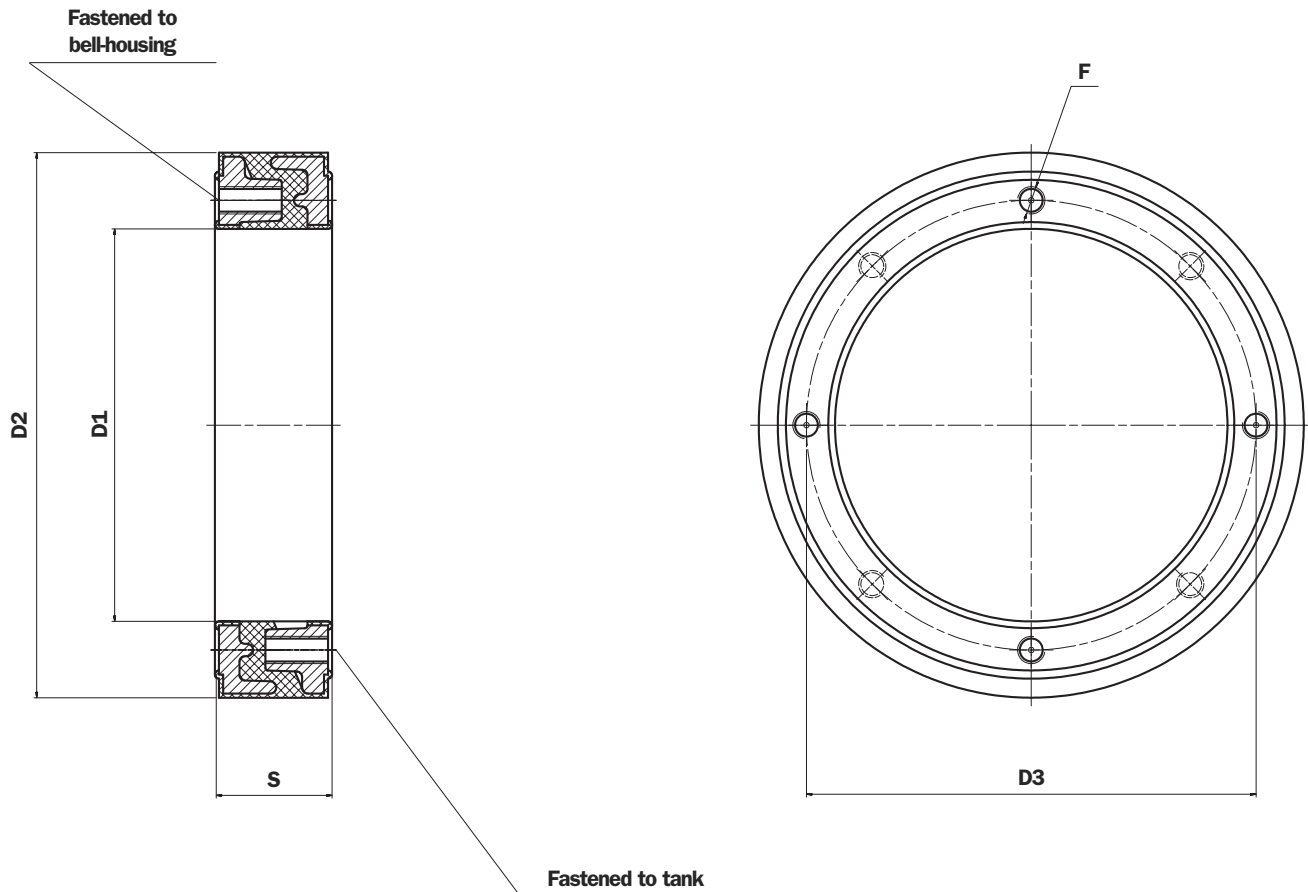

TABLE 46

Foot bracket	D1	D2	D3	S	F	Weight (kg)
ANM A 200	146	200	165	43	M10	1,70
ANM A 250	190	250	215	48	M12	2,53
ANM A 300	239	300	265	53	M12	2,15
ANM A 350	260	350	300	62	M16	3,95

Note: For dimensions other than those indicated in the table, contact the MP Filtri Technical and Sales Department.

.....

.....

.....

.....

.....

.....

Aluminium tanks

Made of pressure diecast aluminium alloy, these tanks feature superior strength and optimum design and are ideal for compact hydraulic power units.

Generously proportioned fins ensure efficient cooling.

The tank is supplied with:

- M6 threaded fixing holes for lid
- feet with M8 threaded fixing holes
- G 3/8" threaded drain hole

The lid is sealed by a gasket made of special paper, which must be ordered separately indicating code "GUS 10,0".

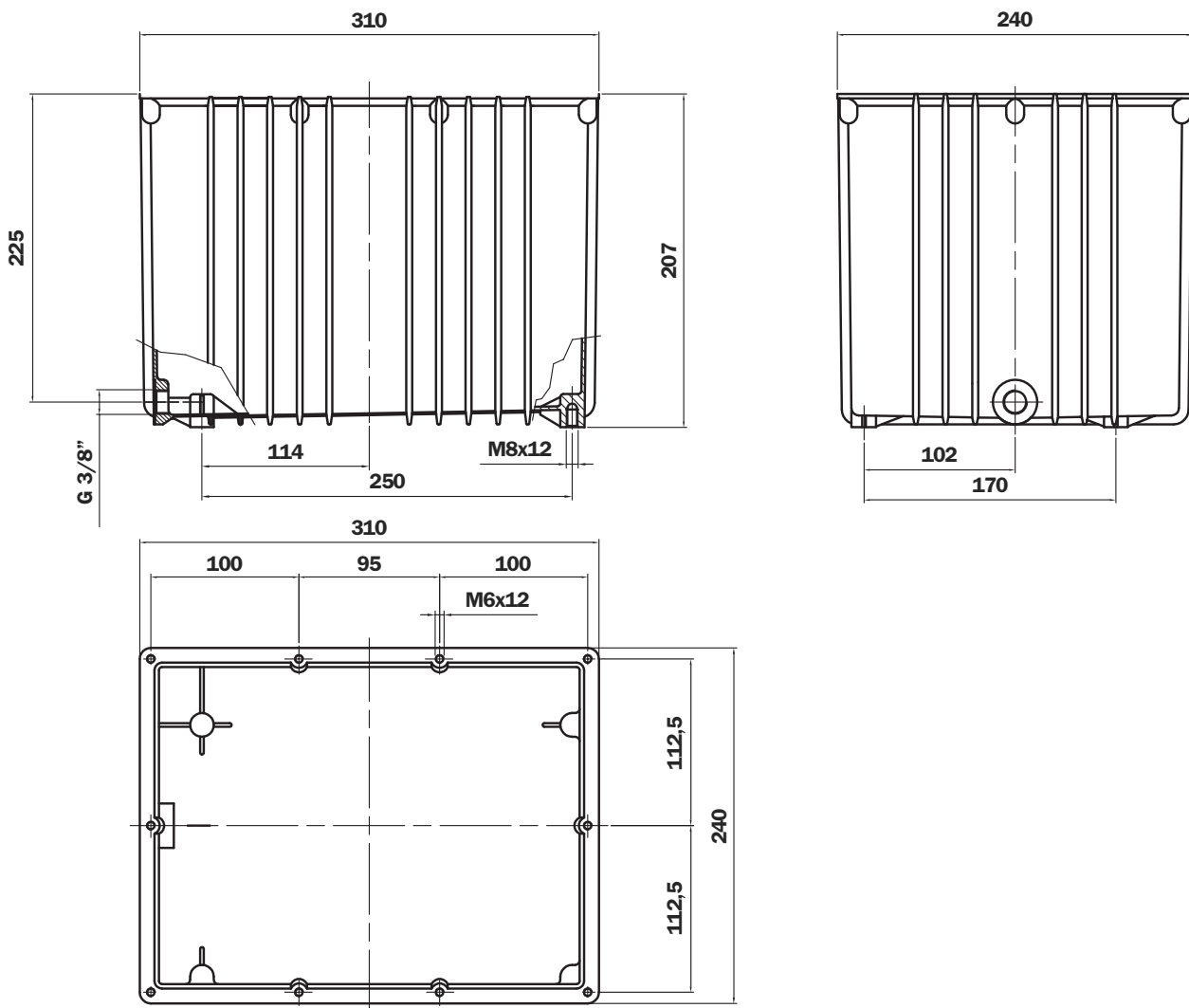

TABLE 47

Code	Weight (kg)
SE10LT	3,95

Inspection doors

These pressure diecast aluminium alloy doors offer superior mechanical strength and are manufactured to DIN 24339 standard. They provide easy access to the inside of the oil tank for inspection and cleaning purposes.

On request and for small quantities, to be agreed with MP Filtri Technical and Sales Department, inspection doors can be supplied with:

- Customer logo.
- Hole cut for visual level indicator.
- Hole cut for visual and electrical level indicator.
- Oil sample plug

Technical specifications

INSPECTION DOORS

Materials

- **Inspection cover**
Pressure diecast aluminium alloy/cast iron
- **Seal**
Oil-resistant rubber, Shore A hardness 70.

Temperature

- $-30^{\circ}\text{C} + 80^{\circ}\text{C}$
For temperatures outside this range, contact the MP Filtri Technical and Sales Department.

Compatibility with fluids

- **Components compatible for use with:**
 - Mineral oils**
Types HH-LL-HM-HR-HV-HC, to ISO 6743/4 standard
 - Water based emulsions**
Types HFAE - HFAS, to ISO 6743/4 standard
 - Water glycol**
Type HFC, to ISO 6743/4 standard
- **Ask for anodized version**

Special Applications

- **Any applications not covered by the normal indications contained in this catalogue must be evaluated and approved by the MP Filtri Technical and Sales Department.**

Reminders for correct fitting of inspection covers

- **The thickness of the tank wall must be at least 4 mm or greater**
- **Observe the specified hole dimensions when drilling tank wall (see next page)**
- **Make certain that after welding stud screws or bolts, the tank wall does not present any noticeable deformation**
- **Thoroughly clean the surface of the wall on which the seal will be seated.**
- **Wet the seal with hydraulic oil to prevent the rubber from cracking**
- **Fit the seal carefully to the inspection cover**
- **Tighten the retaining nuts, torquing to 15 Nm**

Inspection doors

OB275

Tank wall fixing holes

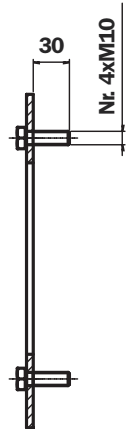
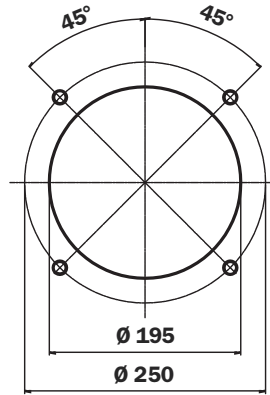
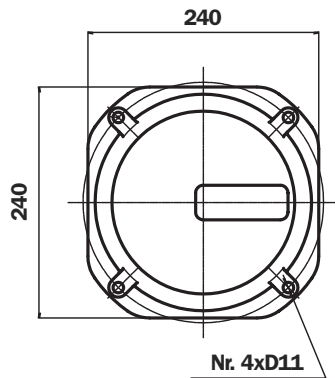

TABLE 48

Code	Weight (kg)
Door with MP Filtri OB275P01	1,76
Blank door OB275P02	
Seal GU0275NBR	
Seal FPM GU275VTN	

OB350

Tank wall fixing holes

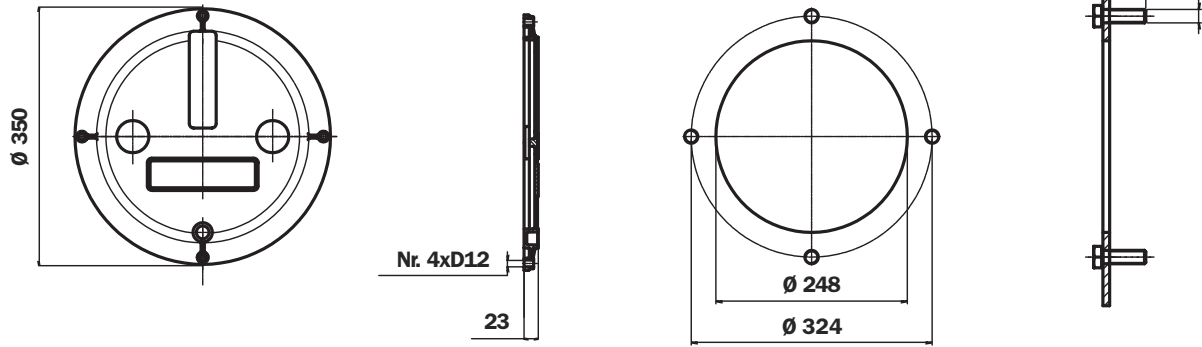

TABLE 49

Code	Weight (kg)
Door OB350DIN000	
Seal GU0350DINNBR	1,80
Seal FPM GU0350DINVTN	

OB356

Tank wall fixing holes

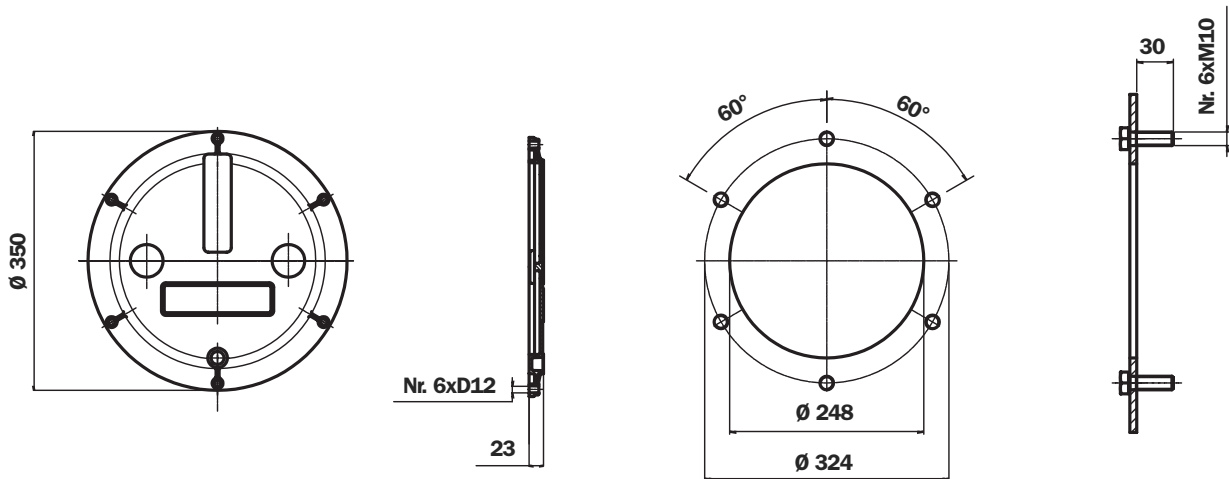

TABLE 50

Code	Weight (kg)
Door OB356DIN000	
Seal GU0350DINNBR	1,80
Seal FPM GU0350DINVTN	

OB400

Tank wall fixing holes

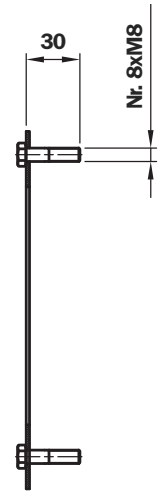
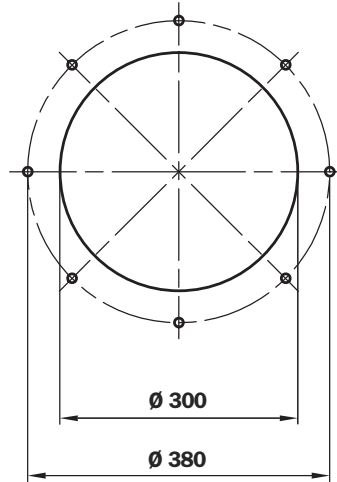
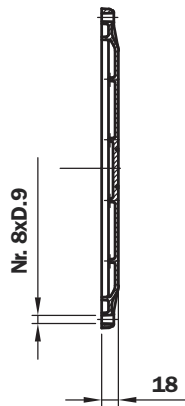
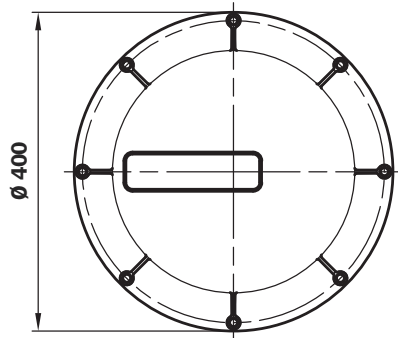

TABLE 51

Code	Weight (kg)
Door with MP Filtri OB400P01	2,90
Blank door OB400P02	
Seal GU0400DINNBR	
Seal FPM GU0400DINVTN	

OB475

Tank wall fixing holes

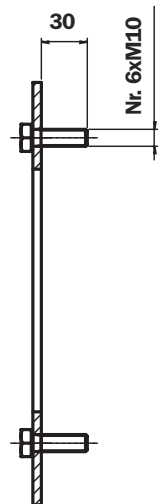
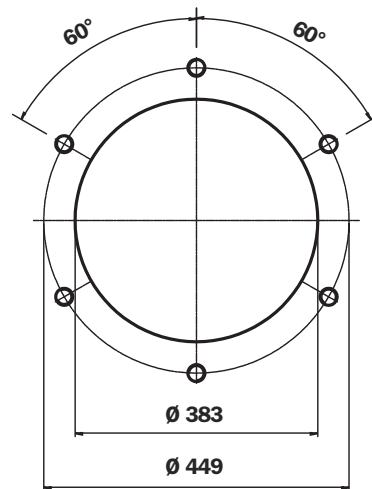
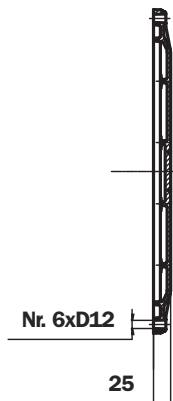
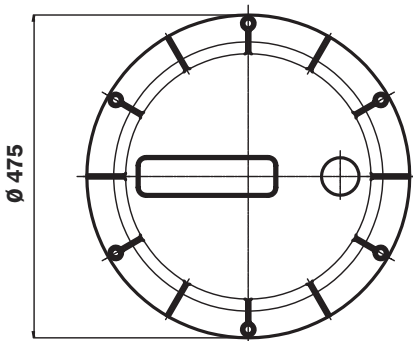

TABLE 52

Code	Weight (kg)
Door with MP Filtri OB475P01	3,40
Blank door OB475P02	
Seal GU0475DINNBR	
Seal FPM GU0475DINVTN	

Seals

Seals made of special paper provide the sealing action between the lid of the oil tank and the bell-housing (motor interface) and between the bell-housing and the pump flange.

They are available for motors from size 63 rated **0.12 kW**, up to **size 180 rated 22 kW**, and for all gear pumps listed in this catalogue.

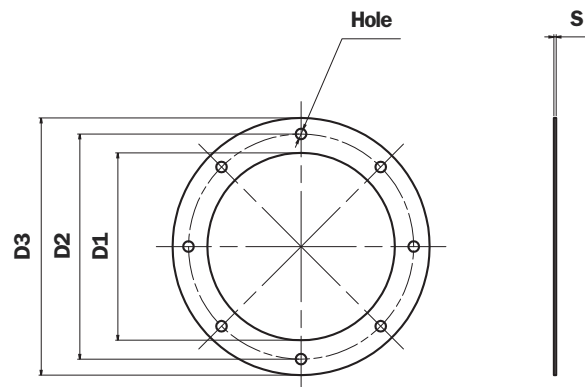

TABLE 53

Bell-housing code	Seals code	D1	D2	D3	S	Hole
LMC 120	GUM P 120	84	100	120	1	7
LMC 140	GUM P 140	96	115	140		9
LMC 160	GUM P 160	110	130	160		9
LMC 200	GUM P 200	145	165	200		11
LMC 250	GUM P 250	190	215	250		14
LMC 300	GUM P 300	234	265	300		14
LMC 350	GUM P 350	260	300	350		18

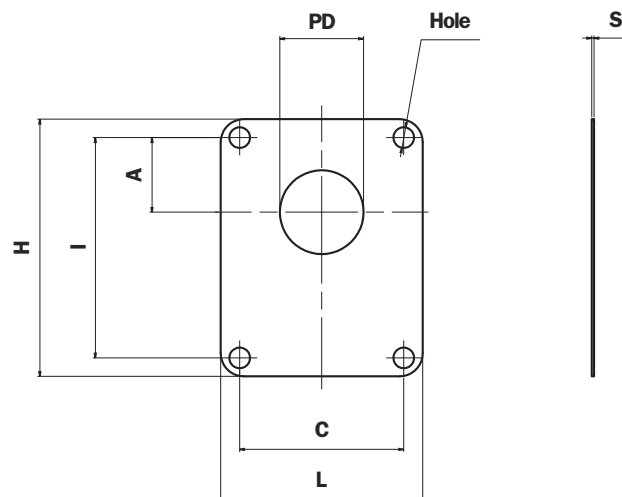

TABLE 54

Pump code	Seals code	PD	A	B	C	H	L	S	Hole
FS05M	GUP P001	22	25.6	66	-	80	48	1	6.5
FS100	GUP P002	25.4	26.6	72	52.4	87	67		6.5
FS1M0	GUP P003	30	24.5	73	56	85	68		6.5
FS200	GUP P004	36.5	32.5	96	71.5	112	88		8.5
FS300	GUP P005	50.8	43	128	98.5	148	118		10.5
FSZBR	GUP P013	32	10.35	40	40	75	62		8.5
FSZFR	GUP P014	80	34.5	100	72	118	90		9

Note: Motor seals and pump seals must be ordered separately,

For seals with dimensions different to those indicated in tables 53 - 54, contact the MP Filtri Technical and Sales Department.

Inspection door options

Visual level indicators LVA series

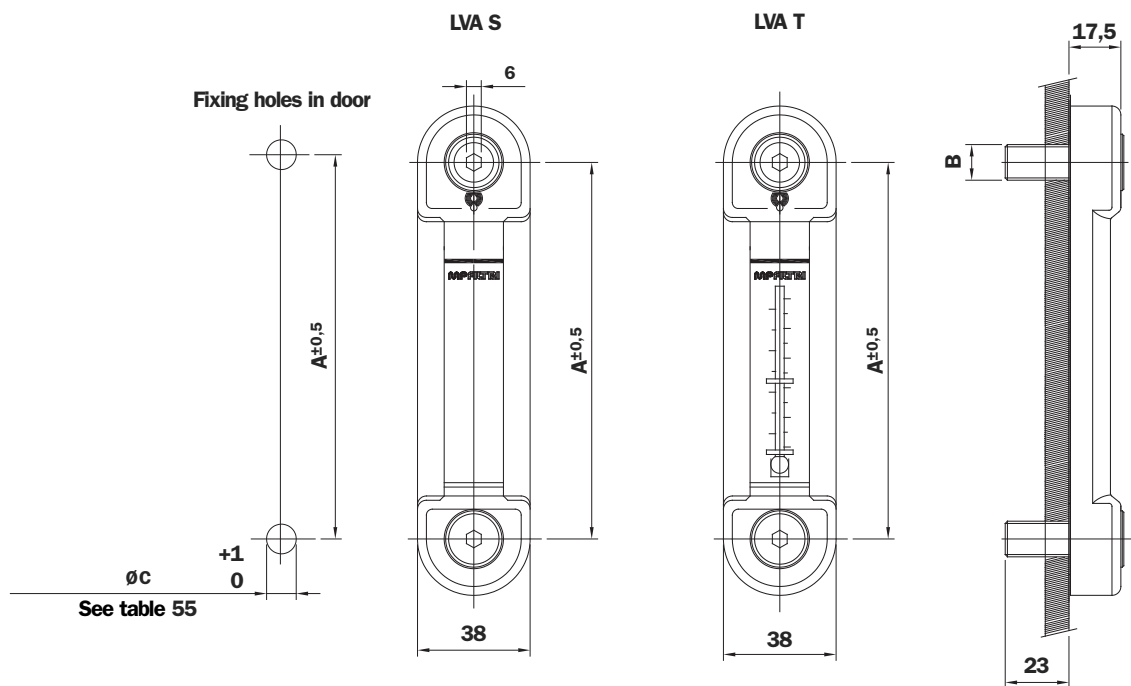
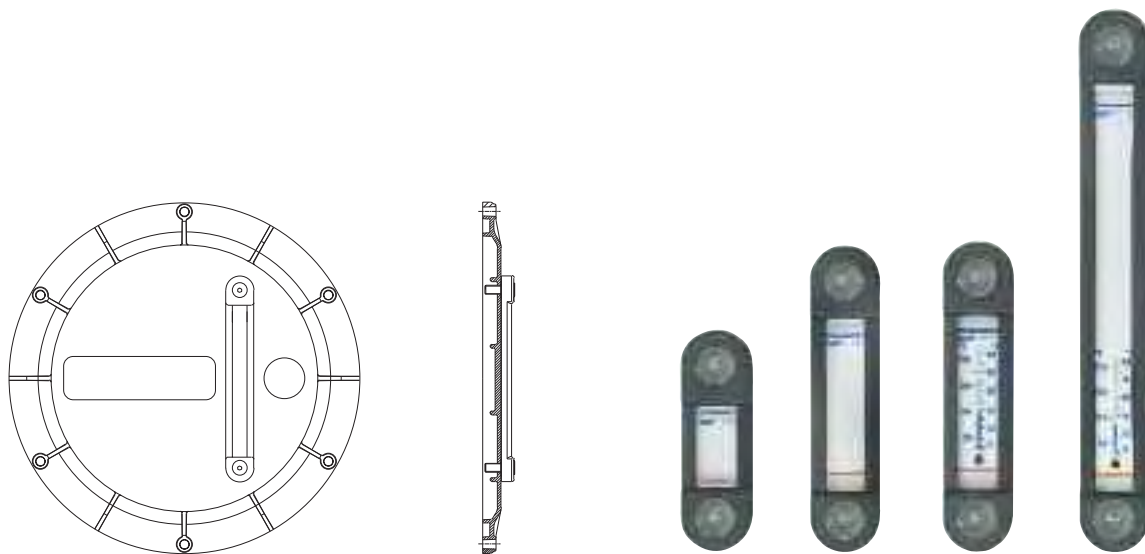

Preparing for to fit the level on request

Code door	Code level
OB275**	LVA 10**
OB350**	LVA 10**
OB356**	LVA 20**
OB400**	LVA 10**
OB475**	LVA 20**
	LVA 30**

TABLE 55

Size	Dimensions		
	A	B	ØC
LVA 10	76	M 10	11
LVA 20	127	M 12	13
LVA 30	254	M 12	13

Materials:

Transparent amorphous polyamide lens
Nylon guard
Seals: Series A-NBR - Series V-FPM

Operating pressure: Max 1 bar at +80 °C

Operating temperature: From -25 °C to +80 °C

Tightening torque: 10 Nm max.

Mineral oils - Synthetic oils - Water base emulsions - Phosphoric esters

Inspection door options

Electrical float level indicators LEG series

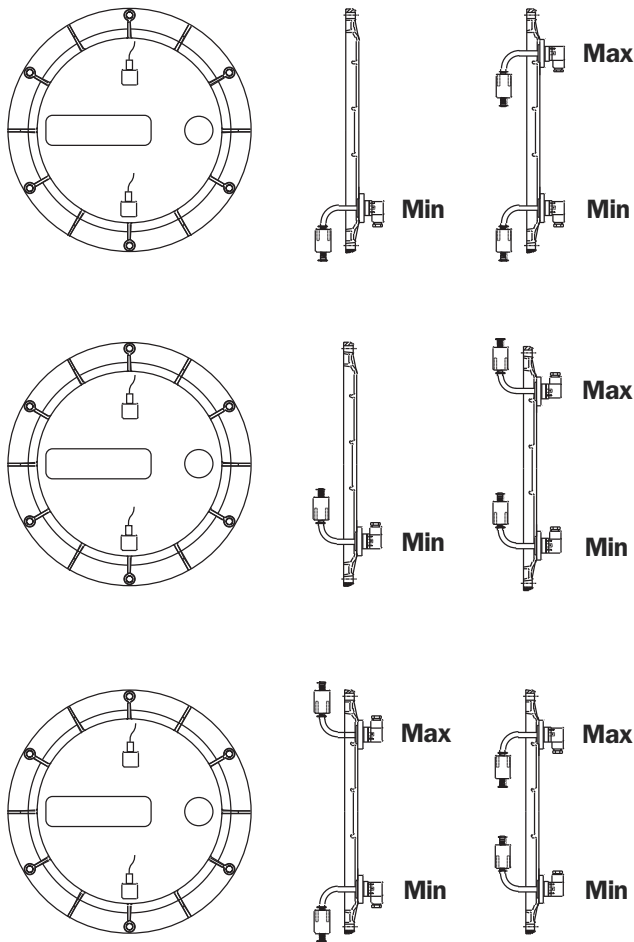

Layout of fixing holes for LEG level indicator

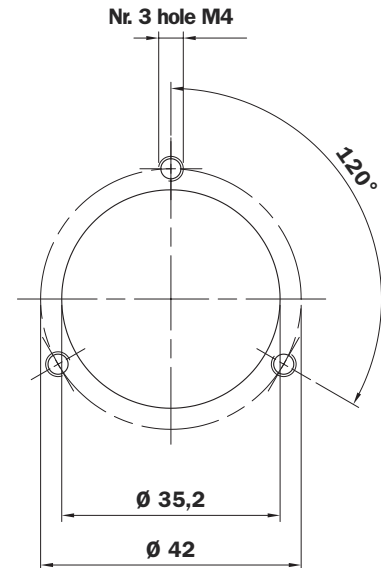

Note: Arrange the holes according to the position of the level indicator

Prepared for visual indicator - on request

Technical specifications

LEG series electrical level indicators are supplied with a 3-hole fixing flange and a reed switch having NC-NO contacts. Designed typically for installation on the vertical walls of oil tanks, these instruments can also be mounted to inspection doors of the OB475 series as indicators of minimum and maximum oil levels in the tank.

DIN 43650 CONNECTOR

Materials

- **Flange**
Aluminum
- **Rod**
Brass
- **Float**
Nylon foam
- **Seals**
A= NBR
V= FPM

Temperature

- -15°C ÷ +80°C
For temperatures outside this range,
contact the MP Filtri Technical and Sales Department.

Warning

To operate correctly, the float must be positioned vertically and at a minimum distance of 35 mm from walls made of ferrous metal.

To change the contact from NC to NO, simply turn the float upside down.

The electrical properties indicated are referred to resistive loads; for capacitive and inductive loads and incandescent lamps, use protection circuits.

Inspection door options

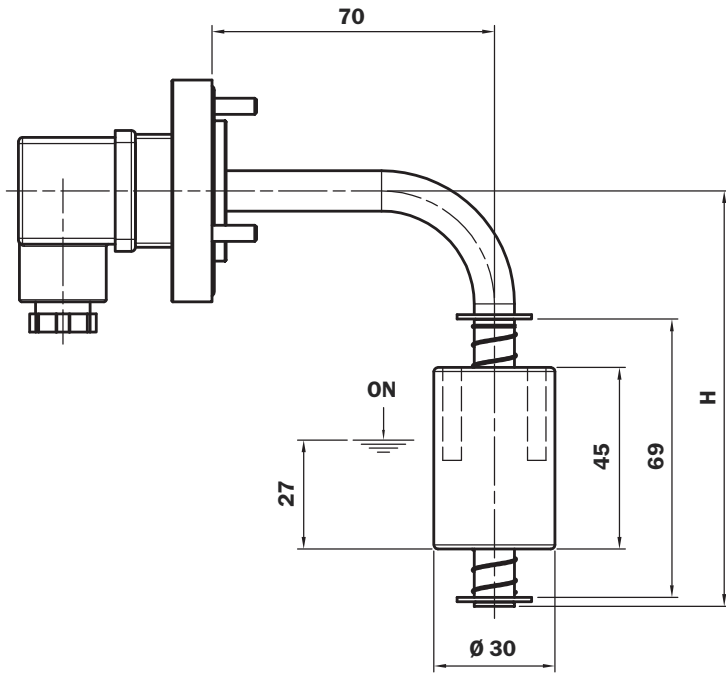

LEG 1 Float



To invert the contact status from NO to NC and vice versa, simply invert the float.

Length	H
103	103
200	200
300	300
350	350

LEG ordering information

Electrical float level indicators series

LEG

Example: LEG

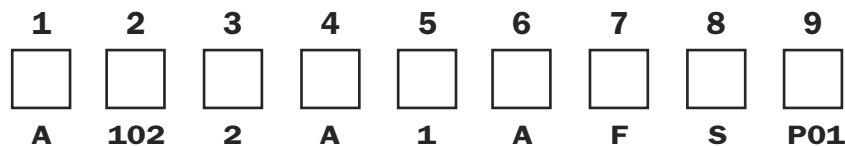

1 - Tube material

A Brass

2 - Length

102

3 - Number of floats

1 Nr. 1 float

4 - Float material

A Nylon foam

5 - Changeover contacts

1 NC

6 - Seals

A NBR

V FPM

7 - Type of fixing

F 3 hole flange

8 - Electrical connection

S DIN 43650 connector

9 - Options

P01 MP Filtri standard

Pxx On request

Note: For customization features other than those indicated on this page, contact the MP Filtri Technical and Sales Department.

Inspection door options

Visual level indicators code: LCP42NS

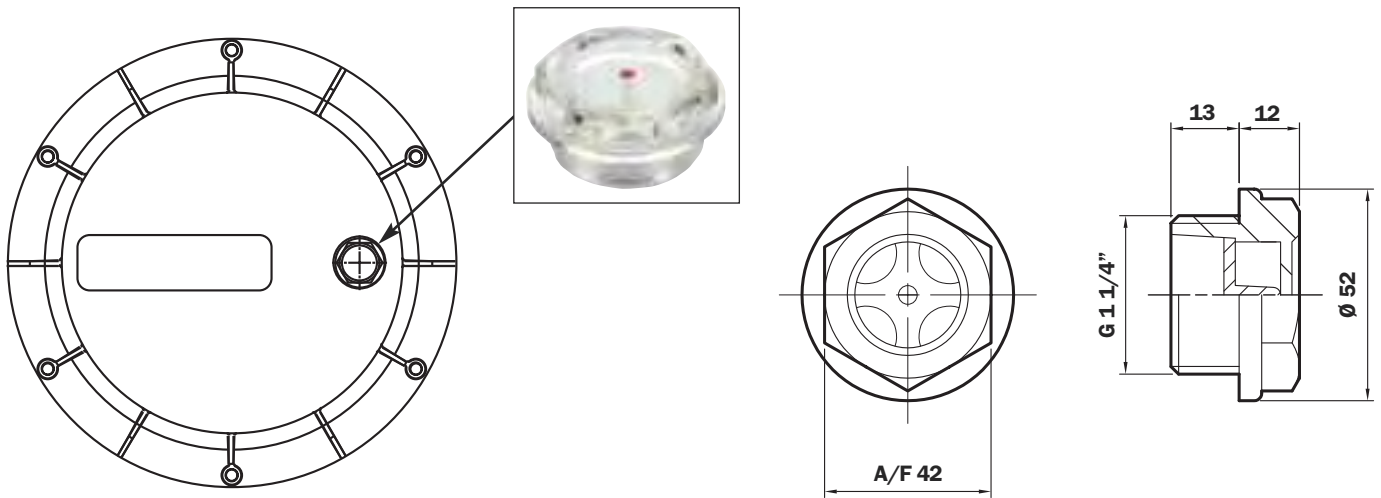

Prepared for electrical indicator - on request

.....

.....

.....

.....

.....

.....

.....

.....

.....

.....

Customizing client

Nameplate with customer logo
Ordering information: **OB475LOGOP05**

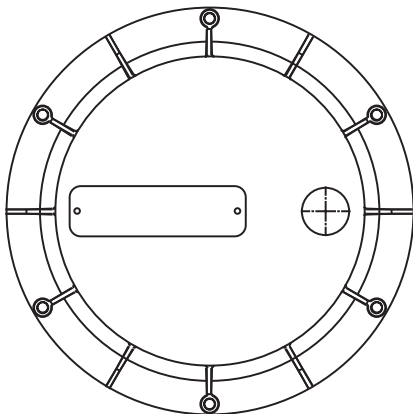

The nameplates applied to the new inspection door are identical to those applied to the old door.
The difference with the new door is that nameplates are fixed with rivets 2 x Ø 4 mm.

For ordering information codes, minimum order quantities, fixing hole positions and other details not indicated in this publication, contact the MP Filtri Technical and Sales Department.

Summary table, electric motors

TABLE 56

8-pole 50 Hz 750 rpm kW	Power						Frame kW	dimensions HP	code kW	Flange dimensions	
	6-pole 50 Hz 1000 rpm HP	4-pole 50 Hz 1500 rpm kW	2-pole 50 Hz 3000 rpm HP	B5/V1 HP	B1/V18 size						
	0,06	0,08	0,12	0,16	0,18	0,24	63	11x23	M01	140	
	0,09	0,12	0,18	0,24	0,25	0,34				90	
0,09	0,12	0,18	0,24	0,25	0,34	0,37	71	14x30	M02	160	
0,12	0,16	0,25	0,34	0,37	0,50	0,55				105	
0,18	0,24	0,37	0,50	0,53	0,75	0,75	80	19x40	M03	200	
0,25	0,34	0,55	0,75	0,75	1,02	1,10				120	
0,37	0,50	0,75	1,02	1,10	1,50	1,50	90	24x50	M04	200	
0,55	0,75	1,10	1,50	1,50	2,04	2,20				140	
0,75	1,02	1,50	2,04	2,20	3,00	3,00	100	28x60	M05	250	
1,50	2,04	2,20	3,00	4,00	5,44	4,00				160	
2,20	3,00	3,00	4,08	5,50	7,50	5,50	132	38x80	M06	300	
3,00	4,08	5,50	7,50	7,50	10,20	7,50				10,20	
4,00	5,44	7,50	10,20	11,00	15,00	11,00	160	42x110	M07	350	
7,50	10,20	11,00	15,00	15,00	20,40	18,00				25,16	
11,00	15,00	15	20,40	18,50	25,16	22,00	180	48x110	M08	350	
				22,00	30,00	30,00				40,80	
15,00	20,40	18,5	25,16	30,00	40,80	30,00	200	55x110	M09	400	
		22,00	30,00			37,00				50,32	
						45,00	225	55x110	M09	450	
18,50	24,18			37,00	50,32						
22,00	30,00	30,00	40,80	45,00	61,20		225	60x140	M10	450	
						55,00	250	60x140	M10	550	
						74,80					
30,00	40,80	37,00	50,32	55,00	74,80		250	65x140	M11	550	
						75,00	280	65x140	M11	550	
						102,00					
37,00	50,32	45,00	61,20	75,00	102,00		280	75x140	M12	550	
45,00	61,20	55,00	74,80	90,00	122,40						
						110,00	315	65x140	M11	660	
						148,60					
55,00	74,80	75,00	102,00	110,00	149,60		315	80x170	M13	660	
110,00	149,60	132,00	179,50	200,00	272,00						
						250,00	355	75x140	M12	800	
						340,00					
132,00	178,52	160,00	217,80	250,00	340,00		355	95x170	M15	800	
20,00	272,00	250,00	340,00	315,00	428,40						
						355,00	400	80x170	M13	800	
						482,80					
						400,00	400	100x210	M16	800	
250,00	340	315,00	428,40	355,00	482,80						
				400,00	544,00						